

October 5, 2023

Board of Commissioners of Public Utilities
Prince Charles Building
120 Torbay Road, P.O. Box 21040
St. John's, NL A1A 5B2

Attention: Jo-Anne Galarneau
Executive Director and Board Secretary

Re: Long-Term Supply for Southern Labrador – Revision 2

Please find enclosed Newfoundland and Labrador Hydro's ("Hydro") revised application for approval of the construction of Hydro's long-term supply plan for southern Labrador pursuant to Section 41(3) of the *Public Utilities Act*.¹

The initial schedule for the in-service date of Hydro's proposal was 2027, based on achieving regulatory approval in the fall of 2023. As the regulatory process is ongoing, there is an associated delay in the timeframe for the major procurement activities Hydro requires to inform its environmental registration and the expected completion of the environmental review process. Hydro has determined that there is a corresponding delay in the beginning of site work by one construction season, and that this shift in project schedule has resulted in marginal cost increases in the project estimate. This updated estimate is reflected in the analysis completed by Midgard Consulting Inc., filed on October 5, 2023² in response to correspondence dated August 1, 2023³ in which the Board of Commissioners of Public Utilities requested that Hydro provide additional information with regards to the analysis of alternatives that would enable reliable supply to the communities of Charlottetown and Pinsent's Arm.

Revision 2 of Hydro's application is filed as an update to the costs and schedule, with the detail included in Schedule 3 to the revised application. Revisions to the application have been shaded grey for ease of reference.

Should you have any questions, please contact the undersigned.

Yours truly,

NEWFOUNDLAND AND LABRADOR HYDRO



Shirley A. Walsh
Senior Legal Counsel, Regulatory
SAW/kd

¹ *Public Utilities Act*, RSNL 1990, c P-47, s 41(3).

² "Newfoundland and Labrador Hydro – 2021 Capital Budget Supplemental Application Approval of the Construction of Hydro's Long-term Supply Plan for Southern Labrador – Revision 1 – Safe and Reliable Power Supply to Charlottetown – Reply," Newfoundland and Labrador Hydro, October 5, 2023, att. 1.

³ "Newfoundland and Labrador Hydro – 2021 Capital Budget Supplemental Application Approval of the Construction of Hydro's Long-term Supply Plan for Southern Labrador – Revision 1 – Safe and Reliable Power Supply to Charlottetown," Board of Commissioners of Public Utilities, August 1, 2023.

Encl.

ecc:

Board of Commissioners of Public Utilities

Jacqui H. Glynn
Cheryl Blundon
PUB Official Email

NunatuKavut Community Council

Jason T. Cooke, KC, Burchell Wickwire Bryson LLP
Sarah L. MacLeod, Burchell Wickwire Bryson LLP

Labrador Interconnected Group

Senwung F. Luk, Olthuis Kleer Townshend LLP
Nicholas E. Kennedy, Olthuis Kleer Townshend LLP

Consumer Advocate

Dennis M. Browne, KC, Browne Fitzgerald Morgan & Avis
Stephen F. Fitzgerald, Browne Fitzgerald Morgan & Avis
Sarah G. Fitzgerald, Browne Fitzgerald Morgan & Avis
Bernice Bailey, Browne Fitzgerald Morgan & Avis

Newfoundland Power Inc.

Dominic J. Foley
Lindsay S.A. Hollett
Regulatory Email

Island Industrial Customer Group

Paul L. Coxworthy, Stewart McKelvey
Denis J. Fleming, Cox & Palmer
Dean A. Porter, Poole Althouse

Revision History

Revision No.	Revision Date	Location	Reason
1	31-May-2023	Legal Application, p. 1, Style of Cause	Updated to reflect revisions made to the application's request.
1	31-May-2023	Legal Application, para. 1, including f.n. 1	Added citation.
1	31-May-2023	Legal Application, para. 3	Update to clarify the number of communities supplied by the proposed project.
1	31-May-2023	Legal Application, para. 4	Updated to reflect past tense and reflect evidence discussed in Schedule 2.
1	31-May-2023	Legal Application, para. 5	Updated to reflect additional options considered as part of the revised application.
1	31-May-2023	Legal Application, para. 6, including f.n. 2.	Updated to reflect past tense.
1	31-May-2023	Legal Application, para. 7	Removed "also."
1	31-May-2023	Legal Application, para. 8	Updated to reflect past tense.
1	31-May-2023	Legal Application, para. 9	Updated to reflect past tense.
1	31-May-2023	Legal Application, para. 10	Updated to reflect past tense. Removal of language no longer relevant to the revised application.
1	31-May-2023	Legal Application, para. 11, including f.n. 3, 4, and 5.	Added to reflect history of proceeding.
1	31-May-2023	Legal Application, para. 12	Added to reflect evidence discussed in Schedule 2.
1	31-May-2023	Legal Application, para. 13, including f.n. 6.	Added to reflect evidence discussed in Schedule 2.
1	31-May-2023	Legal Application, para. 14	Added to reflect evidence discussed in Schedule 2.
1	31-May-2023	Legal Application, para. 15	Added to reflect evidence discussed in Schedule 2.
1	31-May-2023	Legal Application, para. 16	Added to reflect evidence discussed in Schedule 2.
1	31-May-2023	Legal Application, para. 17	Added to reflect evidence discussed in Schedule 2.
1	31-May-2023	Legal Application, para. 18	Added to reflect evidence discussed in Schedule 2.
1	31-May-2023	Legal Application, para. 19	Added to reflect evidence discussed in Schedule 2.
1	31-May-2023	Legal Application, para. 20	Added to reflect evidence discussed in Schedule 2.
1	31-May-2023	Legal Application, para. 21	Added to reflect evidence discussed in Schedule 2.
1	31-May-2023	Legal Application, para. 22	Added to reflect evidence discussed in Schedule 2.
1	31-May-2023	Legal Application, para. 23	Updated to reflect evidence discussed in Schedule 2.
1	31-May-2023	Legal Application, para. 24	Updated to reflect evidence discussed in Schedule 2.
1	31-May-2023	Legal Application, para. 25	Updated to reflect evidence discussed in Schedule 2.
1	31-May-2023	Schedule 2	Schedule 2 added to application package as evidence supporting the revised application.
1	31-May-2023	Affidavit, Style of Cause	Updated to reflect revisions made to the application's request.

Revision No.	Revision Date	Location	Reason
2	5-Oct-2023	Legal Application, para. 15	Updated to reflect additional costs.
2	5-Oct-2023	Legal Application, para. 17	Corrected typographical error.
2	5-Oct-2023	Legal Application, para. 19, including f.n. 7	Added to reflect third-party analysis.
2	5-Oct-2023	Legal Application, para. 26	Updated to reflect third-party analysis.
2	5-Oct-2023	Schedule 3	Schedule 3 added to application package to reflect new costs and scheduling reflected in third-party analysis.



Long-Term Supply for Southern Labrador

Original Application: July 16, 2021

Revision 1: May 31, 2023

Revision 2: October 5, 2023



An application to the Board of Commissioners of Public Utilities

IN THE MATTER OF the *Electrical Power Control Act, 1994, RSNL 1994*, Chapter E-5.1 (“EPCA”) and the *Public Utilities Act, RSNL 1990*, Chapter P-47 (“Act”), and regulations thereunder

IN THE MATTER OF an application by Newfoundland and Labrador Hydro (“Hydro”) for an order approving the construction of Hydro’s long-term supply plan for southern Labrador, pursuant to Section 41(3) of the *Act*.

To: The Board of Commissioners of Public Utilities (“Board”)

THE APPLICATION OF HYDRO STATES THAT:

A. Background

1. Hydro is a corporation continued and existing under the *Hydro Corporation Act, 2007*,¹ is a public utility within the meaning of the *Act*, and is subject to the provisions of the *EPCA*.
2. Since the early 2000s, Hydro has studied the long-term supply options for certain communities in southern Labrador. In particular, Hydro has examined the possibility of interconnection due to the potential for reductions in operating and maintenance costs and improved reliability in the region.
3. There are six neighbouring communities in southern Labrador that are currently supplied by four separate isolated diesel systems: (a) Charlottetown and Pinsent’s Arm, (b) Mary’s Harbour and Lodge Bay, (c) Port Hope Simpson, and (d) St. Lewis (“Southern Labrador Communities”).
4. Hydro’s consideration of the possibility of interconnection of the Southern Labrador Communities has been expedited due to an October 2019 fire at the Charlottetown Diesel Generating Station that left it inoperable. Customers previously served by the Charlottetown Diesel Generating Station were then served by three mobile gensets, a temporary configuration that is considered an interim solution. Since that time, there have been further complications with the service configuration in Charlottetown; a long-term solution is required to address

¹ *Hydro Corporation Act, 2007*, SNL 2007 c H-17.

reliability, safety, and environmental concerns associated with the long-term use of mobile generation in a prime power application.

B. Application

5. A number of options were considered as part of Hydro's evaluation of potential long-term solutions, including (a) the addition of infrastructure to improve reliability for the continued operation of the mobile gensets, (b) the direct replacement of the Charlottetown Diesel Generating Station, (c) the interconnection of the Southern Labrador Communities with supply provided by a single regional diesel generating station in Port Hope Simpson, and (d) interconnection to the Labrador Interconnected System.
6. Schedule 1 to this application provides an overview of Hydro's planned approach to long-term supply for southern Labrador at the time of filing its application "Long-Term Supply for Southern Labrador – Phase 1" ("Original Application") in July 2021.² The economic and technical assessment of the various alternatives that were considered to address the long-term firm supply needs for the Southern Labrador Communities is provided in Attachment 1 to Schedule 1.
7. Hydro considered the potential role of renewable energy resources in its isolated systems. To date, renewable energy technologies, with the exception of hydro generation with reservoir storage, present challenges that limit their viability as primary sources of capacity in isolated systems. While renewable energy sources in their current state are not viable for the provision of firm capacity, these sources can be used to provide energy on an isolated system, reducing the energy required from diesel generation and thereby reducing operating costs such as diesel fuel consumption.
8. The alternatives considered by Hydro, and discussed in Schedule 1, included provisions for future infrastructure required to integrate renewable sources. Alternatives involving the interconnection of multiple isolated systems are expected to further facilitate the integration of renewable energy in the future, as such systems are better suited to absorb fluctuations in supply that are commonly experienced from renewable generation, allowing for a greater penetration of renewable energy on the system.

² "Long-Term Supply for Southern Labrador – Phase 1," Newfoundland and Labrador Hydro, July 16, 2021.

9. Hydro's initial analysis determined that a phased approach to interconnection with a single regional diesel generating station in Port Hope Simpson is the least-cost option. That proposed long-term solution was to be phased in over an approximate 20-year period to align with the replacement schedule of the existing assets. Phase 1 of the originally proposed solution included the construction of a regional diesel generating station in Port Hope Simpson with four diesel gensets and the construction of 50 kilometres of 25 kV distribution line to connect the existing Charlottetown Distribution System. The estimated cost for Phase 1, at the time of filing the Original Application, was \$1.1 million in 2021, \$15.8 million in 2022, \$20.3 million in 2023, and \$12.7 million in 2024, for a total of \$49.9 million.
10. The future phases to interconnect the communities of Mary's Harbour (including Lodge Bay, which is served on the Mary's Harbour Distribution System) in 2030 and St. Lewis in 2045 were estimated to cost an additional \$15.2 million and \$7.5 million, respectively.
11. In correspondence from the Board on April 7, 2022³ and May 16, 2022,⁴ Hydro was requested to provide additional information and analysis to supplement the information that had been filed with its Original Application. The Board also required Hydro to engage an independent expert to assist in the analysis of the options and approach for the provision of service in southern Labrador. Hydro selected Midgard Consulting Inc. ("Midgard") to carry out this analysis. Hydro received the, "Southern Labrador Communities - Integrated Resource Plan," ("Midgard IRP")⁵ on March 28, 2023; the report was filed with the Board on March 31, 2023.
12. Midgard's analysis largely confirmed the conclusions of Hydro's study, as detailed in Schedule 1. Midgard recommended proceeding with the construction of a regional diesel generating station and interconnection of the communities of southern Labrador.
13. Midgard's recommendation differed from Hydro's original proposal in that Midgard suggested full, immediate interconnection of all six communities instead of using a phased approach, as

³ "Newfoundland and Labrador Hydro - 2021 Capital Budget Supplemental Application Approval of the Construction of Phase 1 of Hydro's Long-term Supply Plan for Southern Labrador - To NLH - Further Information Required Before Schedule is Resumed," Board of Commissioners of Public Utilities, April 7, 2022.

⁴ "Newfoundland and Labrador Hydro - 2021 Capital Budget Supplemental Application Approval of the Construction of Phase 1 of Hydro's Long-term Supply Plan for Southern Labrador - Response to Hydro's Letter dated April 26, 2022," Board of Commissioners of Public Utilities, May 16, 2022.

⁵ "Southern Labrador Communities - Integrated Resource Plan," Midgard Consulting Inc., March 28, 2023.

well as the design of the regional diesel generating station with N-1 reliability, rather than designing conservatively with N-2 reliability, as initially proposed by Hydro. Hydro's review of the Midgard IRP and recommendations is detailed in Schedule 2 to this Revised Application.⁶

14. Hydro has accepted the recommendations provided in the Midgard IRP and as a result Hydro is revising its proposal regarding the provision of service to the Southern Labrador Communities. Hydro proposes to proceed with the regional diesel generating station to an N-1 planning standard with immediate interconnection of all four systems, instead of the phased approach proposed in Hydro's Original Application.
15. Hydro's Original Application provided an estimated cost for the proposed construction of Phase 1 totalling \$49.9 million. The additional stages had an estimated cost, at the time of filing of the Original Application, of \$22.7 million; the original total cost of all phases was an estimated \$72.6 million. The current estimate, including the additional distribution infrastructure and the fourth genset associated with the advancement of the full interconnection of all Southern Labrador Communities, is \$87.9 million; the increase is primarily due to inflationary pressures on the cost of labour and materials as well as increases in material lead times resulting in a longer project duration and interest period during construction.
16. Hydro's acceptance of Midgard's recommendations has no net impact on the proposed design of the regional diesel generating station. While the scope change from N-2 to N-1 redundancy results in one less unit required for the generating station, it is counteracted by the additional unit required for the immediate connection of all communities, originally planned for Phase 2, maintaining the initial design plan of four diesel units.
17. Additionally, maintaining the initial design plan for the regional diesel generating station with six engine bays will ensure sufficient footprint to accommodate future load growth and allow for N-2 redundancy if deemed necessary. While the provision of an extra engine bay to accommodate N-2 redundancy has an incremental cost of approximately \$700,000, this is significantly less than the cost of expanding the building footprint in the event that an additional

⁶ "Long-Term Supply for Southern Labrador," Newfoundland and Labrador Hydro, rev. May 31, 2023 (originally filed as "Long-Term Supply for Southern Labrador – Phase 1" on July 16, 2021), ("Revised Application").

engine bay is required. This additional footprint could also be utilized for equipment to support the integration of renewable energy or storage technologies in the future.

18. The detailed scope of the revised proposal is provided in Section 4 of Schedule 2 to this Revised Application, including the project schedule indicating estimated completion in 2027. Hydro notes that this is an aggressive timeline, which is necessary to bring reliable service to Charlottetown and the other Southern Labrador Communities as expeditiously as possible.
19. Given revised timelines for regulatory approval, environmental release, procurement, and engineering design activities, Hydro anticipates that the proposed project would be placed in service in 2028. Hydro notes that this shift in project schedule has resulted in marginal cost increases in the project estimate; the updated estimate is reflected in Midgard's report filed on October 5, 2023,⁷ and is provided in the cost and schedule update attached as Schedule 3 to this revised application.

C. Reasons for Approval

20. The revised proposal for the interconnection of the Southern Labrador Communities, based on Midgard's analysis and Hydro's review of same, is the least-cost option to provide reliable service to those communities, while also being environmentally responsible. Midgard's conclusions, noted by Hydro at Section 3.7.1 of Schedule 2, reference the passage of time since the prior analysis and the resultant reduction in any cost benefit attributable to deferral of the costs related to the planned replacement of the Mary's Harbour Diesel Generating Station. Midgard's report also discusses the impact of increased forecast diesel costs, in favouring scenarios with higher efficiency and increased renewable procurement, which a regional diesel generating station would provide. Additionally, Midgard noted that the fully interconnected system configuration facilitates increased penetration of incremental renewable energy resources. Hydro agrees with Midgard's analysis and believes that Midgard's recommendation is consistent with Hydro's legislated mandate to provide reliable service at least-cost, in an environmentally responsible manner.

⁷ "Newfoundland and Labrador Hydro – 2021 Capital Budget Supplemental Application Approval of the Construction of Hydro's Long-Term Supply Plan for Southern Labrador – Revision 1 – Safe and Reliable Power Supply to Charlottetown – Reply," Newfoundland and Labrador Hydro, October 5, 2023, att. 1.

21. The Midgard IRP highlighted several benefits of interconnecting the communities to a regional diesel generating facility, including operational savings due to reduced fuel consumption, improved system reliability, reduced capital costs, and greater potential for renewable penetration. Midgard noted that completing the interconnected system in full, instead of in stages, would allow for greater penetration of renewable energy, and therefore greater opportunity to offset diesel fuel usage.
22. Midgard's cost-benefit analysis considered both direct costs, such as capital investments and operational expenses, and indirect costs, such as environmental impacts and potential economic benefits. Midgard also carried out a sensitivity analysis considering the impacts of ten variables, including carbon and diesel fuel costs. The resulting analysis suggested that the upfront capital costs of interconnecting the four systems and six communities will be offset by operational savings over a 25-year period, which is consistent with Hydro's Original Application and the analysis detailed in Schedule 2.
23. As noted in Midgard's IRP, their study period was 25 years and indicated that the full immediate interconnection provides savings compared to a long-term mobile option or a community-based diesel generating station of \$16.3 million and \$24.1 million, respectively.
24. The proposed full interconnection, as compared to continued isolated systems operation, results in an incremental increase in revenue requirement in 2030 but is anticipated to generate revenue requirement savings from 2035 onwards.
25. The reliability assessment completed by Hydro determined that a large interconnection would increase the overall system reliability compared to the status quo or to a scenario where each community is supplied by its own individual diesel generating station. This assessment is supported by the findings detailed in the Midgard IRP. It was also concluded that a solution involving the interconnection of Charlottetown, Mary's Harbour, (including Lodge Bay, which is served on the Mary's Harbour Distribution System), Port Hope Simpson, and St. Lewis provides increased flexibility for more renewable energy penetration, therefore providing more potential to offset fuel consumption in the future. This potential was initially discussed in Schedule 1 to the Original Application and was also noted in the Midgard IRP. Indeed, Midgard noted that proceeding with the full interconnection may enable greater renewable penetration sooner than phased interconnection.

D. Hydro's Request

26. Hydro requests that the Board make an Order pursuant to Section 41(3) of the *Act* approving the capital expenditures of \$934,300 in 2023; \$2,636,700 in 2024; \$16,122,800 in 2025; \$37,432,400 in 2026; \$24,615,300 in 2027; and \$6,203,500 in 2028 for the construction of Hydro's long-term supply plan for southern Labrador.

E. Communications

27. Communications with respect to this application should be forwarded to Shirley A. Walsh, Senior Legal Counsel, Regulatory for Hydro.

DATED at St. John's in the province of Newfoundland and Labrador this 5th day of October, 2023.

NEWFOUNDLAND AND LABRADOR HYDRO

Shirley A. Walsh
Counsel for the Applicant
Newfoundland and Labrador Hydro,
500 Columbus Drive, P.O. Box 12400
St. John's, NL A1B 4K7



Schedule 1

Long-Term Supply for Southern Labrador – Phase 1





Long-Term Supply for Southern Labrador – Phase 1



1 Executive Summary

2 The interconnection of the southern Labrador region has been a consideration of Newfoundland and
3 Labrador Hydro’s (“Hydro”) since the early 2000s. Interconnection scenarios have been contemplated
4 due to the potential for operating savings and enhanced reliability, as well as in consideration of the
5 replacement schedule of existing assets. Following the fire that occurred at the Charlottetown Diesel
6 Generating Station in 2019, the interconnection considerations for the region were expedited. Hydro
7 undertook a technical and economical assessment of alternatives to address the long-term firm supply
8 needs for the communities of southern Labrador, included as Attachment 1.

9 The communities of Charlottetown and Pinsent’s Arm (previously served by the Charlottetown Diesel
10 Generating Station) are currently served by mobile generation. This is a temporary configuration and is
11 considered an interim solution. A long-term solution is required to address reliability, safety, and
12 environmental concerns associated with the long-term use of mobile generation in a prime power
13 application.

14 A number of technically viable options were considered as part of Hydro’s study and are outlined in
15 detail in the Attachment 1 and summarized later in this report. These include:

- 16 • The continued operation of the mobiles with the addition of infrastructure to improve reliability;
- 17 • The direct replacement of the Charlottetown Diesel Generating Station; and
- 18 • Southern Labrador interconnection scenarios supplied by a single regional diesel generating
19 station in Port Hope Simpson.

20 A cost-benefit and sensitivity analysis was conducted to determine the most economically feasible
21 option to meet the long-term supply requirements of Charlottetown and the region. Hydro concluded
22 that a phased approach to a 25 kV interconnection with a single large regional diesel generating station
23 in Port Hope Simpson is the least-cost option.

24 The proposed long-term solution is phased in over an approximate 20-year period to align with the
25 replacement schedule of the existing assets. Phase 1, set to be completed in 2024, includes the
26 construction of a regional diesel generating station in Port Hope Simpson with four diesel gensets¹ and

¹ Diesel generating units are referred to as “genset.”

1 the construction of 50 kilometres of 25 kV distribution line to connect the existing Charlottetown
2 distribution system. The estimated cost for Phase 1 is \$1.1 million in 2021, \$15.8 million in 2022, \$20.3
3 million in 2023, and \$12.7 million in 2024, for a total of \$49.9 million. Future phases to interconnect
4 Mary’s Harbour (in 2030²) and St. Lewis (in 2045) are estimated to cost an additional \$15.2 million and
5 \$7.5 million, respectively.

6 Interconnecting four communities in southern Labrador is expected to provide reliability benefits and
7 cost savings over the life of the infrastructure due to the elimination of the requirement to construct
8 three future diesel generating stations, along with a significant reduction in operating costs.

9 The proposed interconnection is anticipated to result in a total decrease of 1.1% and 0.7% to wholesale
10 and retail revenue requirements, respectively, over the period 2024–2050.

11 A reliability assessment was also performed to determine the system reliability impacts associated with
12 a southern Labrador interconnection scenario. This assessment determined that a large interconnection
13 would increase the overall system reliability compared to the status quo, or a scenario where each
14 community is supplied by its own individual diesel generating station. It was also concluded that a
15 solution involving a southern Labrador interconnection of Charlottetown, Mary’s Harbour, Port Hope
16 Simpson, and St. Lewis provides increased flexibility for more renewable energy penetration, therefore
17 providing more potential to offset fuel consumption in the future.

² Hydro will regularly reassess its economic analysis and load forecast in determining the timing and scope of future phases.

Contents

Executive Summary.....	i
1.0 Introduction	1
2.0 Existing Southern Labrador Isolated Systems	2
2.1 Charlottetown.....	3
2.2 Mary’s Harbour	3
2.3 Port Hope Simpson.....	4
2.4 St. Lewis.....	4
3.0 Integration of Renewable Resources	4
4.0 Evaluation of Alternatives.....	5
4.1 Alternative 1: Continued Operation of Mobile Gensets	5
4.2 Alternative 2: New Diesel Plant in Charlottetown.....	5
4.3 Alternative 3a: Southern Labrador Interconnection – Phased Approach (Recommended Approach)	6
4.4 Alternative 3b: Southern Labrador Interconnection – Full Interconnection	7
4.5 Alternative 4: Interconnection to the Labrador Interconnected System.....	7
4.6 Alternative 5: Interconnection with Hydro Generation	8
5.0 Revenue Requirement Impact.....	8
6.0 Recommended Alternative	10
7.0 Project Description	12
7.1 Project Scope	12
7.2 Project Cost Estimate.....	13
7.3 Future Capital Requirements.....	14
7.4 Project Schedule	14
8.0 Conclusion.....	16

List of Appendices

Appendix A: Stakeholder Engagement

List of Attachments

Attachment 1: Long-Term Supply Study for Charlottetown: Economic & Technical Assessment

1.0 Introduction

Since the early 2000s, Hydro has studied the interconnection of the communities of southern Labrador due to its potential to reduce operating and maintenance costs and improve reliability in the region. The 2019 fire that occurred at the Charlottetown Diesel Generating Station, which left the generation facility inoperable, expedited Hydro’s considerations of a regional interconnection solution.

The current configuration of three mobile gensets to meet the capacity requirements of the Charlottetown system is not viable on a long-term basis for the supply of firm, reliable power as these units are not designed for long-term operation in harsh northern climates. In analyzing the alternatives for Charlottetown, Hydro considered alternatives to optimize the overall system configuration in southern Labrador with a long-term view of least-cost, reliable power for the region.

A long-term supply study that includes an economic and technical assessment of the various supply alternatives has been completed and is included as Attachment 1. This study concluded that a phased approach to a 25 kV interconnection of the neighbouring communities of Charlottetown, Port Hope Simpson, Mary’s Harbour, and St. Lewis, with a regional diesel generating station located in Port Hope Simpson is the most beneficial alternative. The primary benefits of this alternative include:

- Reduced operations, maintenance, overhaul, and replacement costs;
- Reduced fuel consumption and bulk fuel storage requirements with an associated reduction in environmental risk;
- Improved overall system reliability and power quality;
- Increased potential for renewable energy penetration; and
- Improved ability to accommodate load growth to support community development.

The interconnection will also enable the return of the mobile gensets in Mary’s Harbour and Port Hope Simpson to their intended use of being dispatched to any diesel generating station requiring additional generation during an emergency situation.³

Hydro has consulted with key stakeholders, including government, community, and regulatory stakeholders, to outline Hydro’s proposed approach for the long-term supply for southern Labrador. The

³ Mobile gensets in Mary’s Harbour and Port Hope Simpson are currently installed to meet summer peaks in both communities.

1 scope of these discussions, along with a listing of stakeholder groups consulted, is presented in
2 Appendix A.

3 The proposed interconnection was referenced in the five-year plan within Hydro’s 2021 Capital Budget
4 Application;⁴ however, Hydro chose to submit an application outside of the normal capital budget
5 process as: (i) further time was required to refine the concept, (ii) Hydro felt it was appropriate to
6 submit the proposal on a standalone basis due to the magnitude of the proposal, and (iii) timely
7 approval is required to avoid delays to the in-service date beyond 2024 and mitigate the risk of potential
8 reliability impacts resulting from further delays.

9 **2.0 Existing Southern Labrador Isolated Systems**

10 There are four neighbouring communities in southern Labrador that are currently supplied by separate
11 isolated diesel systems, namely Charlottetown, Mary’s Harbour, Port Hope Simpson, and St. Lewis,
12 which are illustrated on the map in Figure 1.

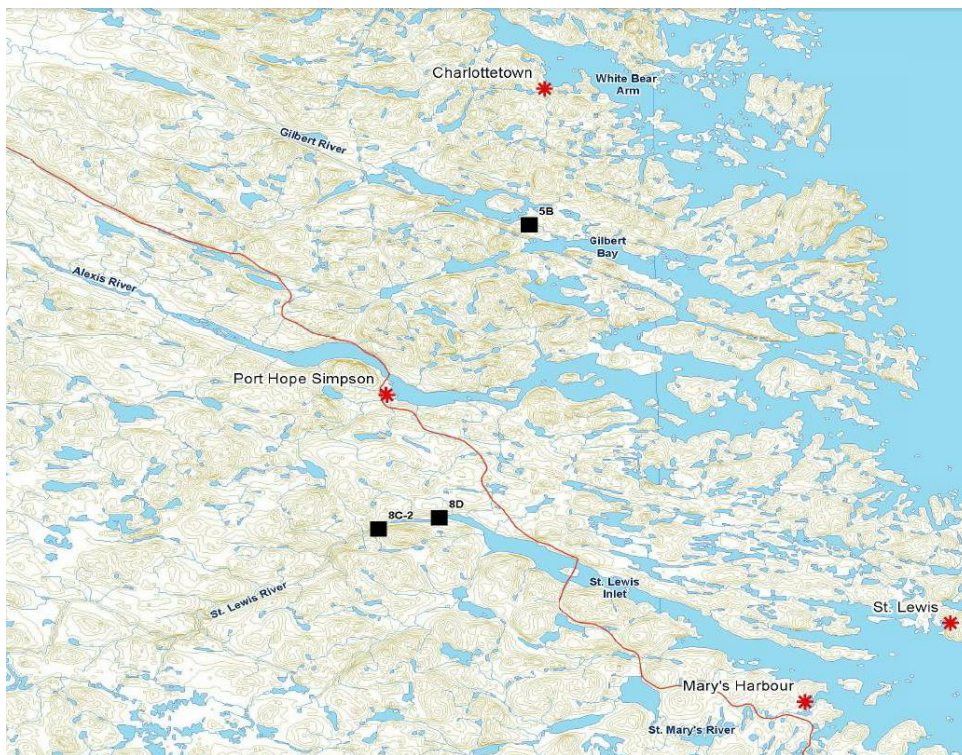

Figure 1: Southern Labrador Isolated Diesel Systems

⁴ “2021 Capital Budget Application,” Newfoundland and Labrador Hydro, rev. 2 November 2, 2020 (originally filed August 4, 2021), 2021–2025 Capital Plan.

1 The isolated diesel generation facilities and associated electrical distribution systems serve as the
2 primary source of power for the residents in each community. Hydro’s reliability planning requirements
3 for diesel generating stations stipulate that sufficient capacity must be in place to support system peak
4 demand with the largest unit out of service. The following are brief descriptions of each existing isolated
5 system.

6 **2.1 Charlottetown**

7 Prior to 2019, the Charlottetown Diesel Generating Station had three diesel gensets inside the
8 powerhouse with an installed capacity of 1,770 kW and two mobile units located outside with an
9 installed capacity of 1,635 kW. The total installed capacity⁵ was 3,405 kW with a total firm capacity of
10 2,495 kW. The mobile units were used in the summer months to support the operation of the local
11 shrimp processing plant.

12 In 2019, the Charlottetown Diesel Generating Station was destroyed by fire, and the area is being served
13 by three mobile diesel generators with an installed capacity of 2,545 kW and a firm capacity of 1,635
14 kW.

15 **2.2 Mary’s Harbour**

16 The Mary’s Harbour Diesel Generating Station has three units with an installed capacity of 1,815 kW and
17 a total firm capacity of 1,090 kW. Customer load requirements exceed this capacity during the crab plant
18 operation between May and November; therefore, one 725 kW mobile generator has been installed
19 outside the diesel generating station to support peak demand requirements, resulting in a total installed
20 capacity of 2,540 kW during the summer months.

21 In addition to its own generation, Hydro has the ability to purchase non-firm energy through a power
22 purchase agreement with St. Mary’s River Energy, an independent power producer which owns and
23 operates a 240 kW mini-hydro plant and is in the process of installing 187.5 kW of photovoltaic solar
24 capacity along with a battery energy storage system.

25 The Mary’s Harbour Diesel Generating Station was placed in service in 1994 and is due for retirement in
26 2030.

⁵ Installed capacity refers to the total installed generation capacity, whereas firm capacity refers to the total installed capacity without the largest unit in service.

1 **2.3 Port Hope Simpson**

2 The Port Hope Simpson Diesel Generating Station has three units with an installed capacity of 1,725 kW
3 for a total firm capacity of 1,000 kW.

4 The Port Hope Simpson Diesel Generating Station was placed in service in 1995 and is due for retirement
5 in 2035.

6 **2.4 St. Lewis**

7 The St. Lewis Diesel Generating Station has three units with an installed capacity of 1,020 kW for a total
8 firm capacity of 565 kW.

9 The St. Lewis Diesel Generating Station was placed in service in 2006 and is due for retirement in 2045.

10 **3.0 Integration of Renewable Resources**

11 In recent years, Hydro has considered the potential role of renewable energy resources in its isolated
12 systems. To date, renewable energy technologies, with the exception of hydro generation with reservoir
13 storage, present challenges that limit their viability as primary sources of capacity in isolated systems.

14 Renewable technologies such as wind generation are non-dispatchable⁶ and therefore require
15 significant energy storage infrastructure to provide firm, reliable capacity. Energy storage technologies
16 have not yet matured to the point that they are a viable alternative for firm, reliable, least-cost provision
17 of power when compared to diesel generation.

18 While renewable energy sources in their current state are not viable for the provision of firm capacity,
19 these sources can be used to provide energy on an isolated system, reducing the energy required from
20 diesel generation and thereby reducing operating costs such as diesel fuel consumption.

21 In order to meet firm capacity requirements for the southern Labrador system, Hydro has considered
22 alternatives to provide firm capacity using diesel generation, small-scale hydro generation, or
23 interconnection to the bulk electrical system, as detailed in Section 4.0. While there is a need for non-
24 renewable sources to meet the system firm capacity requirements, these alternatives do not preclude
25 Hydro from availing of the integration of renewable resources for the provision of energy in the future.
26 The alternatives under consideration by Hydro will include provisions for future infrastructure required

⁶ Non-dispatchable generation refers to intermittent, variable generation sources whereby the supply cannot be adjusted to match demand on the system, potentially leading to capacity shortfalls during periods of reduced renewable energy generation.

1 to integrate renewable sources. Alternatives involving the interconnection of multiple isolated systems
2 are expected to further facilitate the integration of renewable energy as such systems are better suited
3 to absorb fluctuations in supply that are commonly experienced from renewable generation, allowing
4 for a greater penetration of renewable energy on the system.

5 **4.0 Evaluation of Alternatives**

6 The alternatives that were evaluated as part of this proposal are outlined in detail in Attachment 1. A
7 summary of the alternatives follow:

- 8 • Alternative 1: Continued Operation of Mobile Gensets;
- 9 • Alternative 2: New Diesel Plant in Charlottetown;
- 10 • Alternative 3a: Southern Labrador Interconnection – Phased Approach;
- 11 • Alternative 3b: Southern Labrador Interconnection – Full Interconnection;
- 12 • Alternative 4: Interconnection to the Labrador Interconnected System; and
- 13 • Alternative 5: Interconnection with Hydro Generation.

14 **4.1 Alternative 1: Continued Operation of Mobile Gensets**

15 This alternative consists of the continued operation of the mobile gensets to supply power to the
16 Charlottetown area. The other communities of Port Hope Simpson, Mary’s Harbour, and St. Lewis would
17 be unchanged and would continue to operate as isolated systems.

18 Capital upgrades would be required to address deficiencies associated with the current temporary
19 configuration of the mobile gensets in Charlottetown, such as the construction of a building enclosure
20 with necessary ventilation, lighting, and fire suppression systems to house the gensets and operations
21 facilities (i.e., electrical room, control room, battery room, office, bathroom, and workshop).

22 **4.2 Alternative 2: New Diesel Plant in Charlottetown**

23 This alternative consists of the construction of a new isolated diesel generating station at a new location
24 in Charlottetown. The supply for the communities of Port Hope Simpson, Mary’s Harbour, and St. Lewis
25 would be unchanged and would continue to operate as isolated systems.

1 Capital work associated with the new diesel generating station would include site development,
2 construction of a new building enclosure with necessary ventilation, lighting, and fire suppression
3 systems to house the gensets and operations facilities (i.e., electrical room, control room, battery room,
4 office, bathroom, and workshop).

5 **4.3 Alternative 3a: Southern Labrador Interconnection – Phased Approach** 6 **(Recommended Approach)**

7 This alternative involves a phased approach to the interconnection of the southern Labrador systems
8 with a regional diesel generating station. The following is a description of the development phases for
9 this alternative:

10 **Phase 1 (In Service 2024)**

- 11 • Construct a regional diesel generating station in Port Hope Simpson with four gensets installed
12 of the following approximate sizes: one 1,000 kW, two 1,500 kW, and one 1,800 kW;
- 13 • Construct 50 kilometres of 25 kV distribution line to connect Charlottetown;
- 14 • Construct 3 kilometres of 25 kV distribution line to connect Port Hope Simpson; and
- 15 • 25 kV voltage conversion of the Charlottetown and Port Hope Simpson distribution systems.

16 **Phase 2 (In Service 2030)**

- 17 • Install one additional 1,800 kW genset;
- 18 • Construct 50 kilometres of 25 kV distribution line to connect Mary's Harbour; and
- 19 • 25 kV voltage conversion of the Mary's Harbour distribution system.

20 **Phase 3 (In Service 2045)**

- 21 • Construct 30 kilometres of 25 kV distribution line to connect the St. Lewis distribution system;
22 and
- 23 • 25 kV voltage conversion of the St. Lewis distribution system.

4.4 Alternative 3b: Southern Labrador Interconnection – Full Interconnection

This alternative is the same as alternative 3a, with the work completed in a single development phase which would be completed by 2024. The following is a description of the work:

- Construct a regional diesel generating station in Port Hope Simpson with five gensets installed of the following approximate sizes: one 1,000 kW, two 1,500 kW, and two 1,800 kW;
- Construct 50 kilometres of 25 kV distribution line to connect Charlottetown;
- Construct 3 kilometres of 25 kV distribution line to connect Port Hope Simpson;
- Construct 50 kilometres of 25 kV distribution line to connect Mary's Harbour; and
- Construct 30 kilometres of 25 kV distribution line to connect St. Lewis.

4.5 Alternative 4: Interconnection to the Labrador Interconnected System

This alternative consists of the interconnection of the southern Labrador communities to the Labrador Interconnected System near Happy Valley-Goose Bay. This would involve the construction of approximately 400 kilometres of 138 kV transmission line. This new 138 kV transmission line would tap off the existing 138 kV line between Muskrat Falls Terminal Station 3 and the Happy Valley Terminal Station. A new terminal station would be required in Port Hope Simpson to step the voltage down to 25 kV. Construction of the following 25 kV distribution lines would then be required to distribute the power to the four southern Labrador communities:

- 50 kilometres of 25 kV distribution line to connect Charlottetown;
- 3 kilometres of 25 kV distribution line to connect Port Hope Simpson;
- 50 kilometres of 25 kV distribution line to connect Mary's Harbour; and
- 30 kilometres of 25 kV distribution line to connect St. Lewis.

Preliminary cost estimates prepared by Hydro indicate that the total capital cost of such an interconnection would be in excess of \$400 million. Due to the magnitude of this cost, it was not considered further for analysis.

1 **4.6 Alternative 5: Interconnection with Hydro Generation**

2 This alternative consists of the development of two small-scale hydroelectric developments. One site
3 would be located on the Gilbert River, which would have storage, and the other would be located on
4 the St. Lewis River, which would be a run-of-river hydro plant. As outlined in Attachment 1, there are
5 environmental impacts accompanying these two hydro sites that would require significant mitigation.

6 The existing Port Hope Simpson and St. Lewis Diesel Generating Stations would still be required and
7 would remain operational for backup and peaking purposes, since the available firm generation from
8 the hydroelectric sites would not satisfy the forecasted power requirements for all four communities
9 during the winter months.

10 Approximately 150 kilometres of 25 kV distribution line would be constructed to interconnect the
11 generating facilities and communities.

12 Preliminary cost estimates prepared by Hydro indicate that the total capital cost of this alternative
13 would be in the range of \$160 million to \$210 million. This cost does not include operational
14 considerations for the hydro plants, nor for the continued operation and maintenance for the St. Lewis
15 and Port Hope Simpson Diesel Generating Stations. Due to the magnitude of this cost and factors noted,
16 this alternative was not considered further for analysis.

17 **5.0 Revenue Requirement Impact**

18 Hydro has forecasted the net impact of the selected alternative to its revenue requirement in
19 comparison to that of Alternative 1, the continued operation of mobile diesels with associated capital
20 upgrades to support reliable long-term operation. Compared to continued use of mobile generation, the
21 interconnection of the southern Labrador communities is expected to generate an incremental revenue
22 requirement increase of \$1.9 million in 2025 due to higher upfront capital costs. As a result of decreased
23 operating, maintenance, fuel, and overhaul costs,⁷ Hydro forecasts a reduction in net incremental
24 revenue requirements of \$0.9 million in 2035 and \$5.8 million by 2055.⁸ The incremental revenue
25 requirement impacts for Alternative 3a compared to that of Alternative 1 are presented in Figure 2.

⁷ Hydro forecasts a reduction on operating, maintenance, fuel, and overhaul costs of \$1 million in 2035 and \$2.8 million by 2055.

⁸ Hydro's insurance claim relating to the 2019 fire at the Charlottetown Diesel Generating Station is ongoing. Should this claim result in a payment to Hydro, such payment will be applied to reduce the revenue requirement associated with this project.

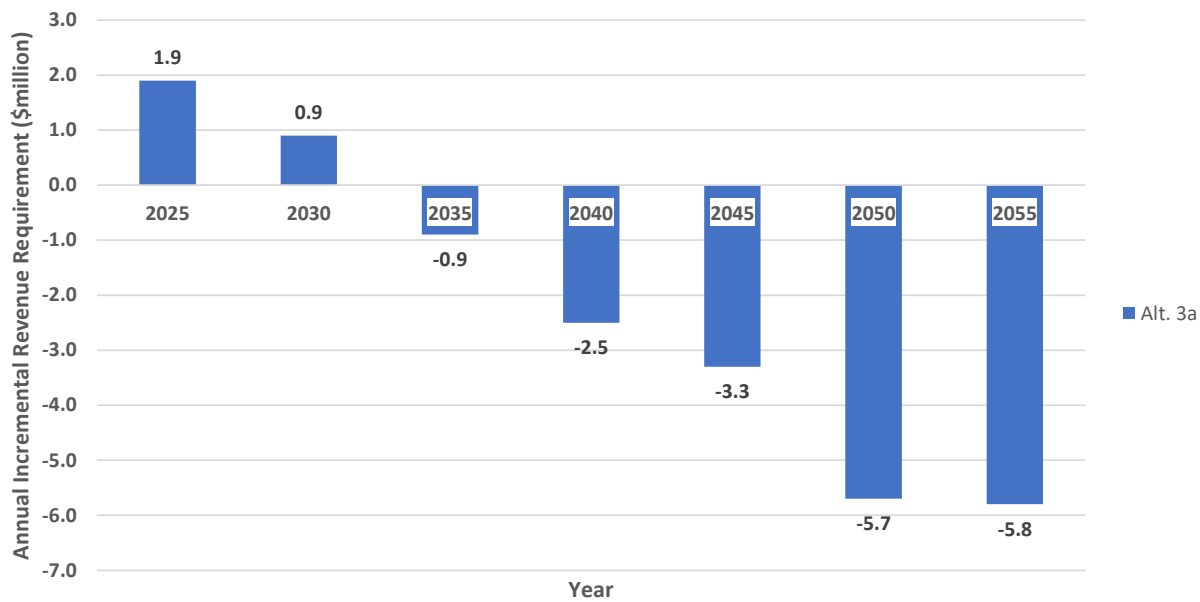

Figure 2: Incremental Revenue Requirements for Interconnection vs. Status Quo

Forecast rate impacts associated with changes in the incremental revenue requirements are presented in Table 1. The forecast is in comparison to the 2019 Test Year and assumes the incremental revenue requirements will be shared between Newfoundland Power and Rural Labrador Interconnected customers in the same proportion which the rural deficit was allocated in the 2019 Cost of Service Study.⁹

Table 1: Forecast Rate Impacts

Customer	2025	2030	2035	2040	2045	2050	2055
Newfoundland Power							
Wholesale	0.4%	0.2%	-0.2%	-0.5%	-0.6%	-1.1%	-1.1%
End Customer	0.2%	0.1%	-0.1%	-0.3%	-0.4%	-0.7%	-0.7%
Rural Labrador Interconnected	0.4%	0.2%	-0.2%	-0.5%	-0.6%	-1.1%	-1.1%

- 1 The interconnection of the southern Labrador distribution systems and implementation of a regional
- 2 diesel generating station is expected to facilitate the potential future integration and penetration of
- 3 renewable energy versus an approach which features individual isolated systems. Should any such
- 4 opportunities arise in the future, it is anticipated that such integration could produce further reduction
- 5 in revenue requirements due to decreased fuel and maintenance costs.

⁹ Newfoundland Power 96.1% and Rural Labrador Interconnected 3.9%.

6.0 Recommended Alternative

As detailed in Attachment 1, Hydro undertook screening and sensitivity analysis of each alternative taking into consideration: the capital cost;¹⁰ operating, maintenance, and overhaul costs; depreciation; asset replacement requirements; and fuel consumption for the 50 years from 2020 to 2070. This analysis determined that the alternatives involving a regional interconnection are the least-cost options. The sensitivity analysis determined that these alternatives would remain least cost provided capital costs for all alternatives did not exceed estimates by more than 100%.

The capital cost estimates for these alternatives were subsequently refined to an American Association of Cost Engineering (“AACE”) Class 3 level¹¹ for further analysis, as presented in Table 2. This further analysis confirmed that Alternatives 3a and 3b are equivalent from a net present value perspective, given the accuracy of an AACE Class 3 estimate. These solutions represent the least-cost alternatives for the long-term supply of the southern Labrador systems. The estimated capital costs and cumulative net present worth of Alternatives 3a and 3b are presented in Table 2. Alternative 3a, which is a phased approach to southern Labrador interconnection, was selected as the most favorable alternative due to its lower execution risk when compared to Alternative 3b, the full interconnection alternative. A phased approach to interconnection will allow Hydro to revise its economic analysis following completion of Phase 1 and assess changes in load forecasts in its evaluation of the timing and scope of future phases, as required. As detailed in Section 5.0, the phased approach to interconnection also balances the short-term revenue requirement impacts with the long-term reduction of revenue requirements expected from interconnection of the southern Labrador communities. The capital cost for Phase 1 of the selected alternative is estimated to be \$49.9 million.

Table 2: AACE Class 3 Capital Cost Estimates

Alternative	Project Phase	In-Service Year	Capital Costs (\$2021)	Cumulative Net Present Worth
3a	Phase 1	2024	\$49,900,000	\$163,185,553
	Phase 2	2030	\$15,200,000	
	Phase 3	2045	\$7,500,000	
	Total		\$72,600,000	
3b	-	2024	\$72,900,000	\$162,914,312

¹⁰ An American Association of Cost Engineering (“AACE”) Class 5 cost estimate was completed.

¹¹ AACE Class 3 estimates require additional project definition and engineering and are considered accurate to -20%/+30%.

- 1 Interconnecting four communities in southern Labrador is expected to provide reliability benefits and
- 2 cost savings over the life of the infrastructure due to the elimination of the requirement to construct
- 3 three future diesel generating stations, along with a significant reduction in operating costs. The phases
- 4 of this alternative are illustrated in Figure 3.

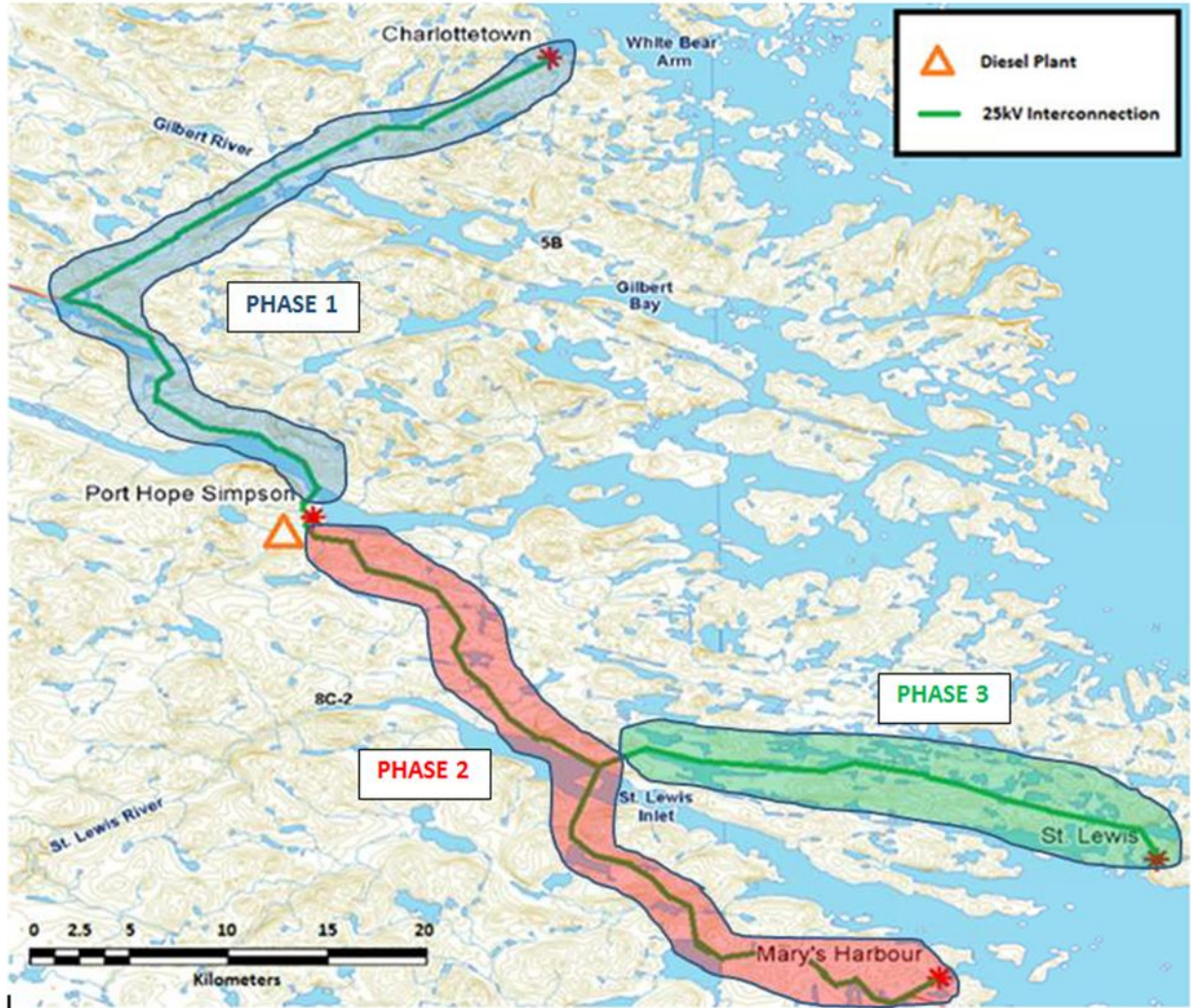

Figure 3: Alternative 3a: Southern Labrador Interconnection – Phased Approach

1 7.0 Project Description

2 7.1 Project Scope

3 The new diesel generating station will be constructed on land adjacent to the existing station in Port
4 Hope Simpson that is owned by Hydro. The installed capacity for Phase 1 will be approximately 5,800
5 kW derived from four 4.16 kV gensets of the following general sizes: (i) one 1,000 kW unit, (ii) two 1,500
6 kW units, and (iii) one 1,800 kW unit. This would translate into a firm capacity of 4,000 kW, which can
7 accommodate the forecasted peak demand of the initial interconnection systems, Charlottetown and
8 Port Hope Simpson.

9 The site will contain a fuel storage area, powerhouse, switchyard, laydown area, septic system, water
10 well, access roads, and perimeter fence. The fuel storage area will include two 80,000 L and two 60,000
11 L double-walled horizontal tanks (total storage 280,000 L). The two 60,000 L tanks are existing tanks that
12 were recently installed at the Charlottetown Diesel Generating Station and will be relocated for use at
13 Port Hope Simpson.

14 The powerhouse building will be of steel and concrete construction. The building will be single storey
15 with a mezzanine housing the control room, office, kitchenette, and washrooms. The ground floor will
16 contain the engine hall, electrical/motor control centre (“MCC”) room, battery room, mechanical room,
17 fire suppression room, and fuel storage room. The building will have fire and sound separations
18 between the engine room, battery room, fuel storage room, and other areas and will mainly be heated
19 by a heat recovery system from the generating units. The control room/office area and MCC room will
20 be cooled with split system air conditioning units and the engine room will be cooled with mechanical
21 ventilation.

22 The engine room will have adequate space to accommodate six diesel units to allow for future
23 expansion should additional capacity be required. An overhead crane will be located in the engine hall to
24 support maintenance activities. The generating units will have remote radiators and exhaust stacks.

25 The 25 kV substation yard will include two 5 MVA 25 kV/4.16 kV transformers, oil containment, and a
26 wood pole structure supporting reclosers, motorized disconnect switches, a 25 kV tension bus, yard
27 lighting, and a 300 kVA 25-0.6 kV station service transformer bank. Unit switchgear, remote unit
28 protection and control panels, black start panel, uninterruptible power supply, battery chargers, and
29 arc-rated MCCs will be located within the electrical room. Power cables from the generating units to

1 switchgear will be in floor trenches and travel overhead from the switchgear to the exterior powerhouse
 2 wall and continue to each transformer in trench.

3 The 25 kV interconnection will include the construction of a new 25 kV distribution line along highway
 4 routes 510 and 514 between Port Hope Simpson and Charlottetown. The line will be approximately 50
 5 kilometres in length and comprised of 477 ASC conductors. A short segment of 25 kV line will also be
 6 constructed to connect to the existing distribution system in Port Hope Simpson. A fibre optic line will
 7 also be installed for communication purposes.

8 Also included are 25 kV voltage conversions for the existing distribution systems in each community, and
 9 installation of a 200 A voltage regulator at the Charlottetown end of the 25 kV interconnection.

10 **7.2 Project Cost Estimate**

11 Hydro completed front end engineering design sufficient to establish a Class 3 cost estimate for Phase 1
 12 of this project. The expected level of accuracy for a Class 3 cost estimate is between -20% and +30%. The
 13 preliminary engineering design included the preparation of design basis documents, development of
 14 single-line diagrams and layouts, development of flow diagrams and piping and instrumentation
 15 diagrams, preparation of specifications and data sheets for identified major equipment, and preparation
 16 of material take offs. With this information, quotes were obtained for major equipment, support
 17 systems were identified and budget pricing obtained, and quantities of materials were estimated.

18 The estimate for Phase 1 is shown in Table 3

Table 3: Project Estimate (\$000)¹²

Project Cost	2021	2022	2023	2024	Total
Material Supply	1.5	5,539.9	7,000.8	3,935.1	16,477.4
Labour	311.5	994.8	928.1	606.8	2,841.3
Consultant	536.6	1,036.9	507.4	340.2	2,421.0
Contract Work	0.0	4,716.1	6,858.4	3,383.4	14,957.9
Other Direct Costs	48.5	928.4	943.3	694.3	2,614.5
Interest and Escalation	46.9	1,105.4	2,421.7	2,693.9	6,267.7
Contingency	109.5	1,498.2	1,673.7	1,023.7	4,305.1
Total	1,054.4	15,819.7	20,333.4	12,677.3	49,884.9

¹² Numbers may not add due to rounding.

1 **7.3 Future Capital Requirements**

2 Phase 2 of the project consists of the installation of one additional 1,800 kW diesel genset in the
3 regional diesel generating station in Port Hope Simpson and construction of 50 kilometres of 25 kV
4 distribution line to interconnect the Mary's Harbour system. The regional diesel generating station will
5 be designed and constructed to accept the additional genset required in Phase 2 with minimal
6 infrastructure work required to install this unit. This work is currently expected to be completed in 2030
7 to coincide with the projected replacement date for the existing Mary's Harbour generating units;
8 however, Hydro will regularly assess changes in its economic analysis and load forecasts in determining
9 the optimal timing and scope of future phases. Phase 2 is estimated to cost approximately \$15.2 million.

10 Phase 3 would include construction of 30 kilometres of 25 kV distribution line to interconnect the St.
11 Lewis system. No additional generating capacity for the regional diesel generating station is required for
12 this phase. This work is expected to be completed in 2045 to coincide with the projected replacement
13 date for the existing St. Lewis generating units. Phase 3 is forecasted to cost approximately \$7.5 million.

14 **7.4 Project Schedule**

15 The following is a brief description of the project execution plan for Phase 1. This plan assumes that
16 project approval of Phase 1 will be granted by the fourth quarter of 2021.

17 Detailed design would begin following approval of this application so that specifications for the major
18 mechanical and electrical equipment can be prepared. Procurement of the major equipment will begin
19 as soon as possible to ensure necessary equipment details are available to support the design of the
20 powerhouse building and site works, which is required to prepare a construction contract package for
21 tender in early 2022. Construction is anticipated to begin in June 2022 and the first season of
22 construction is expected to include completion of the following:

- 23 • Site clearing, grading, and access;
- 24 • Powerhouse foundations and floor slab;
- 25 • Septic field and water well;
- 26 • Site fencing;
- 27 • Substation transformer foundations and containment system;
- 28 • Substation yard and fence grounding;

- 1 • Substation structure installation;
- 2 • Distribution line right-of-way clearing; and
- 3 • Voltage conversion in Charlottetown and Port Hope Simpson.

4 Work will continue in 2023 with the construction of the steel building and installation of the major
 5 equipment including generating units, transformers, and switchgear. Completion of mechanical and
 6 electrical systems will continue after installation of major equipment. Medium voltage cables will be
 7 installed following installation of associated equipment. Distribution line construction is expected to be
 8 substantially complete by the end of 2023. Electrical and mechanical installation inside the building will
 9 continue into the winter of 2023–2024.

10 Pre-commissioning is scheduled to start upon completion of the electrical/mechanical install in mid-
 11 2024. Generating units will be commissioned individually and all systems and gensets are planned to be
 12 in service in the third quarter of 2024.

13 The anticipated Phase 1 project schedule is shown in Table 4, assuming an engineering commencement
 14 date in the fourth quarter of 2021.

Table 4: Project Schedule

Activity	Start Date	End Date
Planning:		
Preliminary engineering, environmental assessment, and project approval	January 2020	Q4 2021
Design:		
Generating station and distribution line engineering	Q4 2021	August 2022
Procurement:		
Major equipment and construction contracts	November 2021	August 2023
Construction:		
Generating station and distribution lines	June 2022	July 2024
Commissioning:		
Commissioning units and auxiliary systems.	July 2024	September 2024
Closeout:		
Contract and project closeout	September 2024	December 2024

8.0 Conclusion

The current system configuration utilizing three mobile generators in Charlottetown is not a viable long-term solution. Due to the circumstance in Charlottetown, Hydro evaluated alternatives, including those that would optimize the overall regional system configuration. Hydro undertook a robust technical and economic analysis (Attachment 1) of alternatives which determined that a phased interconnection of southern Labrador communities starting with Charlottetown and Port Hope Simpson is the least-cost, long-term alternative for customers.

The analysis of alternatives indicates that the proposed interconnected solution has the lowest overall cost and affords many other benefits, including:

- Reduced operations, maintenance, overhaul, and replacement costs;
- Reduced fuel consumption and bulk fuel storage requirements with an associated reduction in environmental risk;
- Improved overall system reliability and power quality;
- Improved ability to accommodate load growth to support community development; and
- Increased potential for renewable energy penetration as renewables can be more easily integrated into larger systems that are less sensitive to fluctuations in supply or demand.

The proposal presented in this application aligns with Hydro's mandate per the *Electrical Power Control Act* to provide service at the "lowest possible cost consistent with reliable service" and supports the reduction of diesel consumption while allowing for the potential integration of renewable generation sources in the future.

Appendix A

Stakeholder Engagement

1 Stakeholder Engagement Sessions

2 Hydro has consulted with key stakeholders, including government, community, and regulatory
 3 stakeholders, to outline Hydro's proposed approach for the long-term supply for southern Labrador. The
 4 purpose of these discussions was to provide an overview of Hydro's plan to interconnect the
 5 communities of southern Labrador, including the justification, alternatives considered, and timing, along
 6 with the benefits that interconnection provides. Stakeholder engagement contributes to regulatory
 7 efficiency by enabling the exchange of information and incorporation of stakeholder feedback, where
 8 possible, in advance of filing an application with the Board. A listing of stakeholders consulted is
 9 provided below.

External Stakeholder	Meeting Date
Department of Industry, Energy, and Technology	December 9, 2020 and February 19, 2021
Office of Indigenous Affairs	April 12, 2021
Office of Labrador Affairs	April 12, 2021
MHA Lisa Dempster	April 12, 2021
Town of Port Hope Simpson	May 4, 2021
Town of Charlottetown	May 5, 2021
Town of Mary's Harbour	May 6, 2021
MP Yvonne Jones	May 7, 2021
Town of St. Lewis	May 12, 2021
Newfoundland Power	May 26, 2021
Dennis Browne	May 27, 2021
Labrador Interconnected Group	June 11, 2021

10 In addition to those consulted to date, Hydro extended an offer to meet with the following stakeholders:

- 11 • Nunatukavut Community Council;
- 12 • Combined Councils of Labrador; and
- 13 • Labrador Fisherman's Union Shrimp Company Ltd.



Attachment 1

Long-Term Supply Study for Charlottetown: Economic & Technical Assessment



Long-Term Supply Study for Southern Labrador: Economic & Technical Assessment

June 10, 2021

A report to the Board of Commissioners of Public Utilities



Contents

1.0	Introduction	1
2.0	Background	1
2.1	Existing Systems.....	1
2.1.1	Diesel Plants.....	2
2.1.2	Distribution Systems.....	3
2.2	Load Forecast	3
2.3	Southern Labrador Interconnection	4
3.0	Future Considerations for the Long-Term Supply of Southern Labrador	6
3.1	Hydraulic Potential in Southern Labrador	6
3.1.1	Site 5B.....	9
3.1.2	Site 8C-2	12
3.2	Mobile Generation Philosophy	14
3.3	Modularization.....	17
3.4	Diesel Generating Station Replacements	18
3.5	Operations and Maintenance and Fuel Costs.....	19
3.6	Consideration for Renewable Energy Integration.....	20
3.7	Reliability Assessment	21
3.8	Motor Starting – Voltage Flicker	21
3.9	Low Voltage Conditions	22
4.0	Summary of Technically Viable Alternatives.....	22
4.1	Alternative 1: Continued Operation of Mobile Gensets	22
4.2	Alternative 2: New Diesel Generating Station in Charlottetown	23
4.3	Alternative 3a: Southern Labrador Interconnection – Phased Approach	25
4.4	Alternative 3b: Full Interconnection of Southern Labrador	29
4.5	Alternative 4: Interconnection to the Labrador Interconnected System.....	30
4.6	Alternative 5: Interconnection with Hydro Generation	31
5.0	Economic Evaluation of Alternatives.....	32
5.1	Alternatives.....	32
5.2	Study Assumptions	33
5.2.1	Capital Costs	33

5.2.2	O&M and Overhaul Costs	34
5.2.3	Depreciation	34
5.2.4	Asset Replacement/Overhaul Schedules	35
5.2.5	Fuel Consumption	35
5.3	Study Results.....	36
6.0	Sensitivity Analysis.....	39
6.1	Project Capital Costs.....	40
6.2	Operations and Maintenance and Overhaul Costs.....	43
6.3	Fuel Price and Plant Efficiency.....	44
6.4	Load Growth	44
6.5	Other Economic Factors.....	45
6.6	Summary	46
7.0	Conclusion and Recommendations.....	46

List of Appendices

Appendix A: Operating Load Forecast (2020–2070)

Appendix B: Southern Labrador – Renewable Energy Study

Appendix C: Southern Labrador Interconnection – Reliability Assessment

Appendix D: Rural Planning Standard – Rural Isolated Systems Generation Planning Criteria

Appendix E: Single-Line Diagrams

Appendix F: Diesel Fuel Price Forecasts (2020–2070)

1.0 Introduction

Newfoundland and Labrador Hydro's ("Hydro") consideration of long-term supply solutions for southern Labrador commenced in the early 2000s. Interconnection options have been an ongoing consideration to support system reliability and mitigate operating and maintenance costs in the region on a long-term basis. The 2019 fire at the Charlottetown Diesel Generating Station left the generation facility inoperable and an interim solution (i.e., mobile gensets)¹ was implemented. The installed mobile gensets are not designed to withstand the severe winter weather conditions associated with this region and, consequently, a long-term plan is required.²

The requirement for a long-term solution for Charlottetown expedited Hydro's consideration of interconnection options for the southern Labrador region. Hydro has evaluated various long-term solutions including:

- The continued operation of the mobile gensets with measures for improved reliability;
- The replacement of the Charlottetown Diesel Generating Station; and
- Southern Labrador interconnection options supplied by a single regional diesel generating station in Port Hope Simpson.

A southern Labrador interconnection would involve the connection and 25 kV voltage conversion of the Charlottetown, Port Hope Simpson, Mary's Harbour, and St. Lewis distribution systems. An economic analysis was performed to determine the least-cost options and a sensitivity analysis was performed to assess the risk and impact associated with changes in various factors.

2.0 Background

2.1 Existing Systems

This section provides an overview of the existing isolated electrical systems in the southern Labrador region. Each of the four southern Labrador communities (Charlottetown, Mary's Harbour, Port Hope Simpson, and St. Lewis) is supplied power by its own isolated electrical grid that consists of an isolated diesel generating station and distribution system.

¹ Diesel generating units are referred to as "genset."

² Since the fire at the Charlottetown Diesel Generating Station, minor upgrades were completed in an attempt to minimize the reliability concerns until the execution of long-term solution. Please refer to "Charlottetown Diesel Generating Station Preparation for Winter Operation – Final Report," Newfoundland and Labrador Hydro, March 9, 2020.

2.1.1 Diesel Plants

The diesel generating stations serve as a primary source of power for the residents in each community and surrounding areas. The diesel generating stations are comprised of three or more diesel gensets with supporting auxiliary systems. There is enough generation capacity in each diesel generating station to support system peak demand even with the largest unit out of service. This required amount of capacity is referred to as firm generation capacity.

The Mary’s Harbour and Port Hope Simpson Diesel Generating Stations are currently designed to accommodate the installation of three 500 kW class diesel units, which would yield a designed firm capacity of 1,000 kW. The diesel generating station in Mary’s Harbour has exceeded its design capacity and therefore mobile gensets have been installed outside of the diesel generating station to help support peak demand conditions, which occurs in the summer during crab processing plant operation.

The St. Lewis Diesel Generating Station is designed to physically support four 500 kW class diesel units, which would yield a firm capacity of 1,500 kW. The Charlottetown Diesel Generating Station is no longer in operation due to the fire and has been replaced with three mobile diesel gensets.³ This mobile arrangement and its limitations are described in Section 3.2.

Table 1 summarizes the installed (total), design (total minus mobiles), and firm (total minus largest unit) capacities of the Charlottetown, Mary’s Harbour, Port Hope Simpson, and St. Lewis Diesel Generating Stations.

Table 1: Diesel Generating Station Capacities

Ratings	CHT^{4,5}	MSH⁶	PHS^{7,8}	SLE⁹
Installed Capacity (kW)	2,545	2,540	1,725	1,020
Design Plant Capacity (kW)	N/A ¹⁰	1,500	1,500	2,000
Firm Capacity (kW)	1,635	1,815	1,000	565

³ Including two 910 kW units and one 725 kW unit.

⁴ Charlottetown (“CHT”).

⁵ This assumes the current arrangement with just mobile gensets.

⁶ Mary’s Harbour (“MSH”).

⁷ Port Hope Simpson (“PHS”).

⁸ There is some potential to increase the Port Hope Simpson design capacity to 1,750 kW but the original design was based on three 500 kW units.

⁹ St. Lewis (“SLE”).

¹⁰ The design capacity in Charlottetown was 1,500kW prior to the fire.

1 **2.1.2 Distribution Systems**

2 The electrical distribution systems in each community are responsible for delivering power directly to
3 the customer. The diesel generating stations for these four communities generate power at a voltage of
4 600 V. The voltage is then stepped up by pole-mounted substation transformers to achieve the desired
5 distribution voltage for each system. The distribution voltage for the Charlottetown and Mary’s Harbour
6 systems is 4.16 kV, while the distribution voltage for St. Lewis and Port Hope Simpson is 12.5 kV. Each
7 system only has one distribution feeder that is electrically protected by a three phase recloser. The
8 distribution lines are comprised of various conductors sizes which include 1/0 AASC, 4/0 AASC and 477
9 ASC.

10 **2.2 Load Forecast**

11 The base case load forecast assumes steady state economic conditions with no changes to the current
12 electricity rate structure and no substantive changes in the relative energy prices of electricity verses
13 locally delivered fuels for customers in Charlottetown, Mary’s Harbour, Port Hope Simpson, and St.
14 Lewis. The annual system peaks for Port Hope Simpson and St. Lewis occur in the winter months;
15 however, the peak of the combined systems would occur in the summer, as the demand is driven by
16 seasonally-operated crab and shrimp processing plants located in Charlottetown and Mary’s Harbour.
17 An integrated system results in having to serve a higher average demand but a lower overall peak
18 demand due to the added diversity of the combined systems.

19 A 20-year summary for the base case load forecast (net¹¹ demand and energy) is provided in Table 2. An
20 extended 50-year base case load forecast is provided in Appendix A.

¹¹ The total gross demand minus station service load.

Table 2: Operating Load Forecast (2020) – Base Case (Net)

Year	Net Demand (kW)					Net Energy (MWh)				
	CHT	MSH	PHS	SLE	Combined ¹²	CHT	MSH	PHS	SLE	Combined
2020	1,501	1,212	625	329	3,556	4,982	4,854	3,261	1,474	14,571
2021	1,507	1,218	627	329	3,571	5,002	5,021	3,275	1,474	14,773
2022	1,513	1,221	629	329	3,582	5,022	5,033	3,283	1,474	14,813
2023	1,520	1,224	631	329	3,592	5,043	5,044	3,292	1,474	14,853
2024	1,526	1,227	632	329	3,602	5,063	5,055	3,300	1,474	14,893
2025	1,532	1,230	634	329	3,613	5,084	5,067	3,308	1,474	14,933
2026	1,535	1,233	635	329	3,620	5,091	5,079	3,318	1,474	14,963
2027	1,537	1,236	636	329	3,626	5,099	5,092	3,328	1,474	14,993
2028	1,539	1,239	637	329	3,632	5,106	5,105	3,338	1,474	15,024
2029	1,542	1,242	638	329	3,638	5,114	5,117	3,348	1,474	15,054
2030	1,542	1,244	639	329	3,642	5,122	5,128	3,358	1,474	15,082
2031	1,543	1,247	640	329	3,646	5,129	5,138	3,368	1,474	15,110
2032	1,545	1,249	641	329	3,652	5,137	5,148	3,378	1,474	15,138
2033	1,548	1,252	642	329	3,657	5,145	5,159	3,388	1,474	15,166
2034	1,550	1,254	643	329	3,663	5,153	5,169	3,399	1,474	15,194
2035	1,551	1,257	643	329	3,667	5,155	5,179	3,409	1,474	15,218
2036	1,552	1,257	644	329	3,669	5,158	5,182	3,419	1,474	15,233
2037	1,552	1,258	645	329	3,671	5,160	5,184	3,429	1,474	15,248
2038	1,553	1,259	646	329	3,674	5,163	5,187	3,440	1,474	15,264
2039	1,554	1,259	647	329	3,676	5,165	5,190	3,450	1,474	15,279

1 **2.3 Southern Labrador Interconnection**

2 The concept of a southern Labrador interconnection has been studied since the early 2000s with the
3 primary objective of assessing the technical and economically feasible options for supplying power to
4 the southern Labrador communities of Charlottetown, Mary’s Harbour, Port Hope Simpson, and St.
5 Lewis. A 25 kV interconnection of these four communities, supplied by a single generation source has
6 the potential to reduce operating and maintenance costs in the region. In the late 2000s, Hydro engaged
7 Hatch Limited (“Hatch”), an external consultant, to study the feasibility of supplying such an
8 interconnected system with diesel and/or hydro generation.

¹² The combined demand reflects the expected coincident summer demand for all systems combined and is not equal to the sum of individual system peaks.

1 The following are the two most noteworthy studies which were requested by Hydro and were
2 completed by Hatch in 2013:

3 **Feasibility Study of Hydraulic Potential of Coastal Labrador¹³**

4 The study provided three technically viable options that involved multiple hydroelectric developments
5 which were capable of almost completely supporting the aggregated forecasted demand of the four
6 southern Labrador communities. Hatch concluded that the least-cost and preferred option was the
7 generation scheme that included the Sites 5B and 8C-2 on the Gilbert and St. Lewis Rivers, respectively.
8 Figure 1 identifies the location and relative distances between the four communities in southern
9 Labrador. The locations of the proposed hydro plants are also included on the map and are labelled as
10 Sites 5B and 8C-2. Capital and operating cost estimates were prepared by Hatch for each hydro
11 development. The combination of both hydro plants would not provide enough firm capacity to the
12 system and therefore diesel generation was still necessary for this proposed option. This hydro option
13 has since been removed from consideration due to cost and environmental reasons with explanations
14 provided in Section 3.1.

15 **Southern Labrador Communities New Diesel Schemes¹⁴**

16 An investigation of the costs and viability of new diesel power generation in the southern Labrador
17 region was evaluated by Hatch in 2013. Hydro requested that two options be considered in this study;
18 namely, a single centralized diesel generating station located at Port Hope Simpson, or three small
19 distributed diesel generating stations located at each of the towns of Charlottetown, Mary's Harbour,
20 and Port Hope Simpson. The cost estimates were classified as Association for the Advancement of Cost
21 Engineering ("AAACE") Class 3 level estimates.

¹³ "Feasibility Study of Hydraulic Potential of Coastal Labrador – Phase 2: Project Definition Phase & Annex (Potential Storage) – Final Report," Hatch Ltd., March 2013.

¹⁴ "Newfoundland and Labrador Coastal Labrador Energy – Southern Communities New Diesel Schemes – Class 3 Cost Estimates," Hatch Ltd.



Figure 1: Southern Labrador Map

1 **3.0 Future Considerations for the Long-Term Supply of**
2 **Southern Labrador**

3 The purpose of this section is to outline some of the key considerations during the development of long-
4 term supply solutions for southern Labrador. These topics had a significant influence on the scope of the
5 alternatives described in Section 4.0.

6 **3.1 Hydraulic Potential in Southern Labrador**

7 Hydro concluded, based on the Hydraulic Potential of Coastal Labrador study performed by Hatch, that
8 the most favorable hydraulic generation scenario in the southern Labrador region includes two

1 hydroelectric developments. This option has the potential of providing the majority of the energy and
2 demand requirements to the communities of Charlottetown, Mary's Harbour, Port Hope Simpson, and
3 St. Lewis. This option would include the development of two small-scale hydro plants, one on the Gilbert
4 River (Site 5B) with hydraulic storage and a run-of-river plant on the St. Lewis River (Site 8C-2).

5 Site 5B is located approximately 12 kilometres due south of Charlottetown on the Gilbert River and
6 would have a dam to provide energy storage for the proposed southern Labrador electrical grid. This
7 proposed plant would consist of two 1,250 kW Kaplan units resulting in an installed capacity of 2,500 kW
8 and an estimated firm capacity of 2,300 kW, which could support a large portion of the total system load
9 of southern Labrador.

10 The proposed run-of-river hydro plant at Site 8C-2 would complement Site 5B and provide the
11 generation required to support the majority of the load of Port Hope Simpson, Mary's Harbour,
12 Charlottetown, and St. Lewis. Site 8C-2 is located approximately 11 kilometres due south of Port Hope
13 Simpson on the St. Lewis River. This proposed plant would consist of two 1,500 kW Kaplan units
14 resulting in an installed capacity of 3,000 kW. The power and energy assessment for this run-of-river
15 scheme indicated that its firm capacity is variable and would likely require supplementary capacity
16 during low flow periods. Installing storage at this site would require higher dams, which may be
17 considered unacceptable, given it would result in unacceptable upstream flooding; therefore, the option
18 of constructing higher dams to provide additional capacity was removed from consideration.

19 As indicated by preliminary flow data gathered at Site 8C-2, the water resources are limited during the
20 winter season and therefore less firm power would be available. Further water flow analysis would be
21 required for confirmation. Based on historical data collected for a critical dry period (Winter 1987), it
22 was determined that the available firm generation from both hydro sites may not satisfy the forecasted
23 power requirements for all four communities during the winter months. The firm generation available
24 for both sites during a critical dry winter period is estimated to be approximately 3,095 kW, with 795 kW
25 from Site 8C-2 and 2,300 kW from Site 5B. The failure of a hydro unit would even further jeopardize the
26 ability to support peak demand; therefore, the newer existing Port Hope Simpson and St. Lewis Diesel
27 Generating Stations would still be required and remain operational for backup and peaking purposes.
28 Although these plants are relatively new, it has been determined that upgrades would be necessary to
29 maximize the amount of power that could be delivered to the larger aggregated system.

1 Under this supply option, these two hydroelectric developments and the four communities would be
2 interconnected to form an isolated grid with a standard distribution line voltage of 25 kV. This
3 interconnection would require approximately 150 kilometres of distribution line carrying 477 kmil ASC
4 conductors. Due to the length of these lines and the distribution of electrical load, two bi-directional
5 voltage regulators would be required for additional voltage support. The arrangement of this
6 interconnection is superimposed on a map of Labrador and is shown in Figure 2.

7 The distribution system voltage of each individual community would be converted to 25 kV to reduce
8 losses, improve voltage levels and increase fault levels for motor starting.

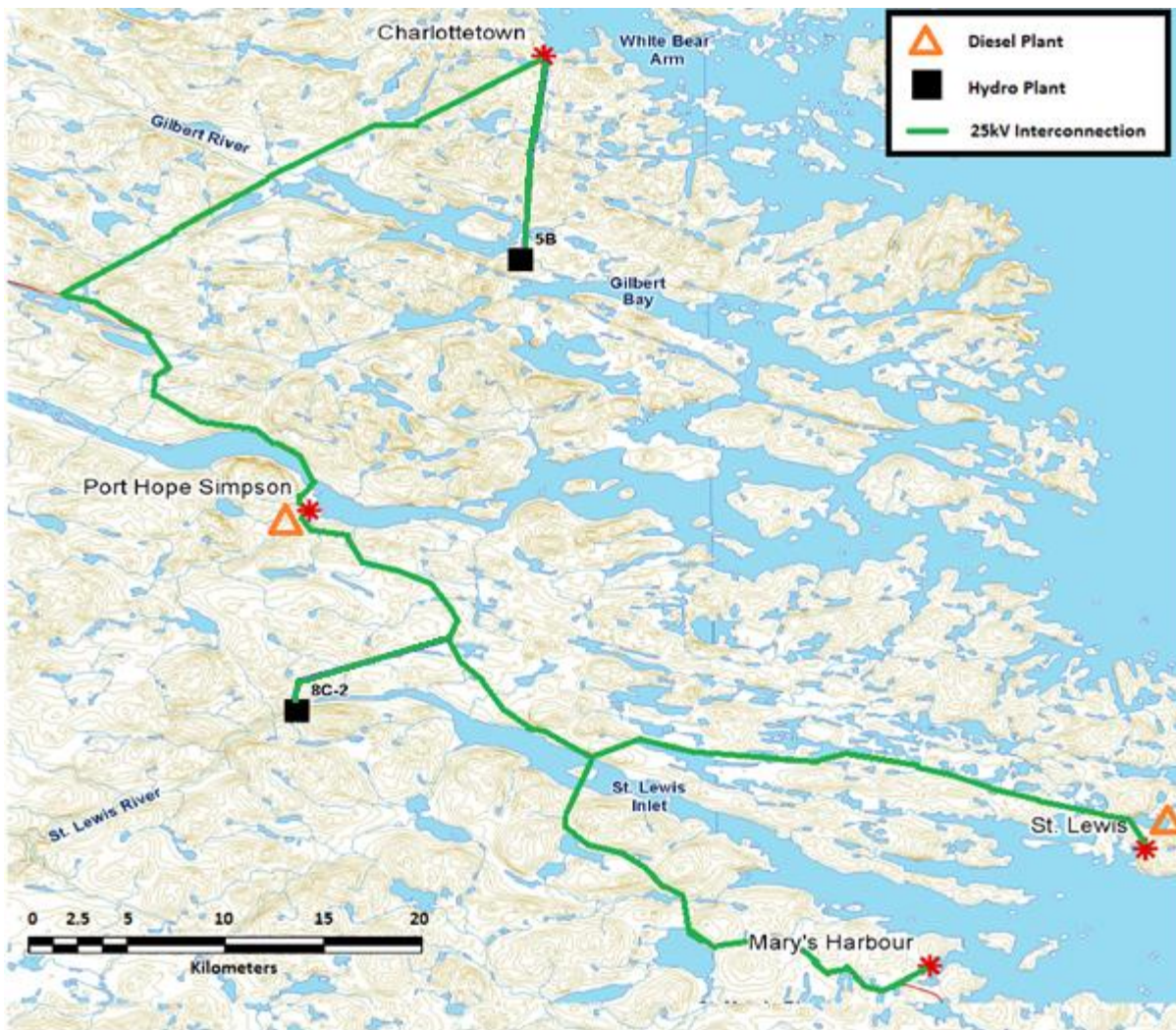

Figure 2: 25 kV Interconnection – Hydro Option

1 The construction and operation of small-scale hydro plants can have a significant impact on the
2 environment which must be considered at the early stages of development. To ensure environmental
3 requirements are satisfied, the following are some of the mandatory activities that Hydro would have to
4 perform for both hydro developments:

- 5 • Phase 1: aquatic and terrestrial field studies, public and agency consultation, impact statement,
6 mitigation measures, assessment of residual effects, environmental management plan;
- 7 • Phase 2: environmental assessment report preparation, issue draft report for submission to
8 agency for approval, and final report, with input from public consultation;
- 9 • Publishing Notice of Completion (once Environmental Assessment approved) separately for each
10 site implemented; and
- 11 • Provincial and federal approvals (permitting process).

12 The proposed small-scale hydro sites both have separate unique environmental challenges that would
13 have to be mitigated. Hydro considers it likely that the hydraulic options involving Site 5B and Site 8C-2
14 would not pass the environmental assessment process.

15 **3.1.1 Site 5B**

16 The proposed hydro development at Site 5B would be located on the Gilbert River which feeds into the
17 Gilbert Bay. The Gilbert Bay is protected under the *Oceans Act* and the Gilbert Bay Marine Protected
18 Area Regulations. On October 11, 2005, the Gilbert Bay was labelled as a Marine Protected Area
19 (“MPA”) under the *Oceans Act*, to conserve and protect a genetically rare population of Atlantic Cod
20 (“Golden Cod”) which carries out most of its life cycle within the boundaries of the bay. The location of
21 the proposed hydro site, Site 5B, in relation to the designated MPA is shown in Figure 3. A development
22 of a hydroelectric dam at this site and its associated flooding of the headwaters could contradict Section
23 3 of the regulations as stated below:

24 Prohibited Activities

- 25 3 (1) In the Area, no person shall
26 (a) disturb, damage or destroy, or remove from the Area, any living marine
27 organism or any part of its habitat; or

1 (b) carry out any activity — including depositing, discharging or dumping any
2 substance, or causing any substance to be deposited, discharged or dumped —
3 that is likely to result in the disturbance, damage, destruction or removal of a
4 living marine organism or any part of its habitat.¹⁵

5 There are exceptions to these regulations such as educational or scientific activities as well as aboriginal
6 fishing with restrictions. The proposed location of the Site 5B powerhouse is located in or adjacent to
7 the marine protected area. The boundary of the most sensitive area, Zone 1, ends approximately one
8 kilometre upstream from the proposed powerhouse site. The dam for this site would be located just
9 outside the boundary of Zone 1, as shown in Figure 3. It is likely that damming of the river would be
10 considered a prohibited activity. Hydro’s interpretation of the regulations suggests that any commercial
11 or hydroelectric development would not be approved through the environmental assessment process.

12 If the environmental assessment process were to result in project approval, Hydro estimates that the
13 costs associated with mitigating or accommodating all environment requirements for Site 5B, as
14 described above, could cost in the order of \$10,000,000. Further studies and monitoring would also be
15 required to confirm the environmental feasibility of a small-scal hydro plant on the Gilbert River to
16 determine if deviation from regulations is possible at a reasonable cost.

¹⁵ SOR/2005-295.

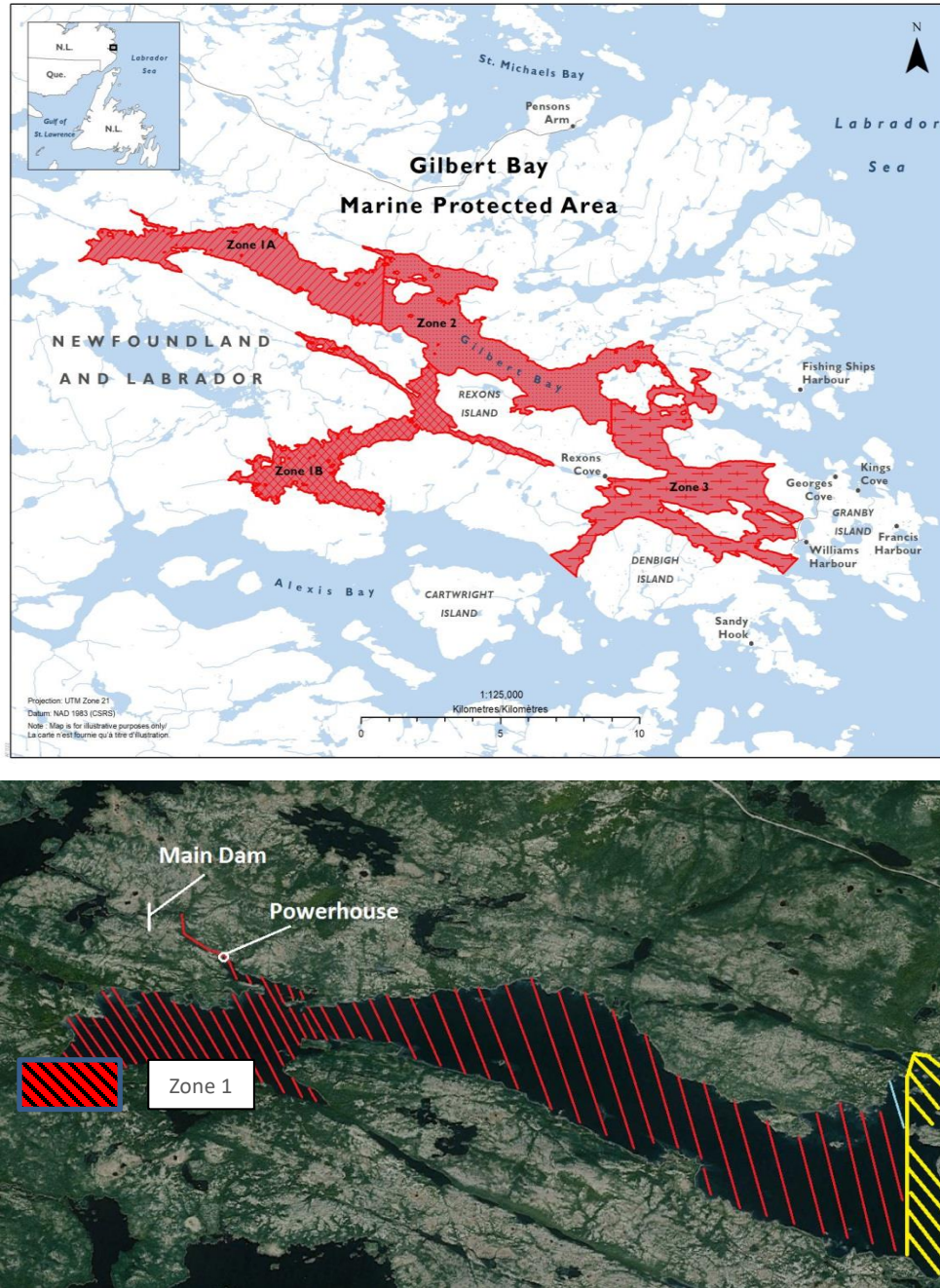

Figure 3: Gilbert Bay Marine Protected Area¹⁶

¹⁶ Courtesy of Fisheries and Oceans Canada <<https://www.dfo-mpo.gc.ca/oceans/images/mpa-zpm/gilbert/GilbertBay-mpa-zpm-eng.jpg>>.

1 **3.1.2 Site 8C-2**

2 Although Site 8C-2 is not located within environmentally sensitive area, it is situated about four
3 kilometres upstream of a privately owned and operated sports fishing lodge named the “St. Lewis River
4 Lodge” (Figure 4). There is concern that a hydro plant would cause downstream flooding that may
5 impact fishing on this river. A hydro plant at Site 8C-2 would be a run-of-river plant, which typically
6 results in minimal flooding, as reservoir storage is not applicable; however, all environmental and social
7 impacts (including those affecting the fishing lodge) would require confirmation through an
8 environmental assessment process. A hydro plant on this river would require an access road, which
9 would make the area more accessible to the general public. Hydro estimates that the environmental
10 mitigation costs associated with Site 8C-2 would be in excess of \$7,000,000. The location of the run-of-
11 the river plant with respect to the fishing lodge is shown in Figure 5.



Figure 4: St. Lewis River Lodge

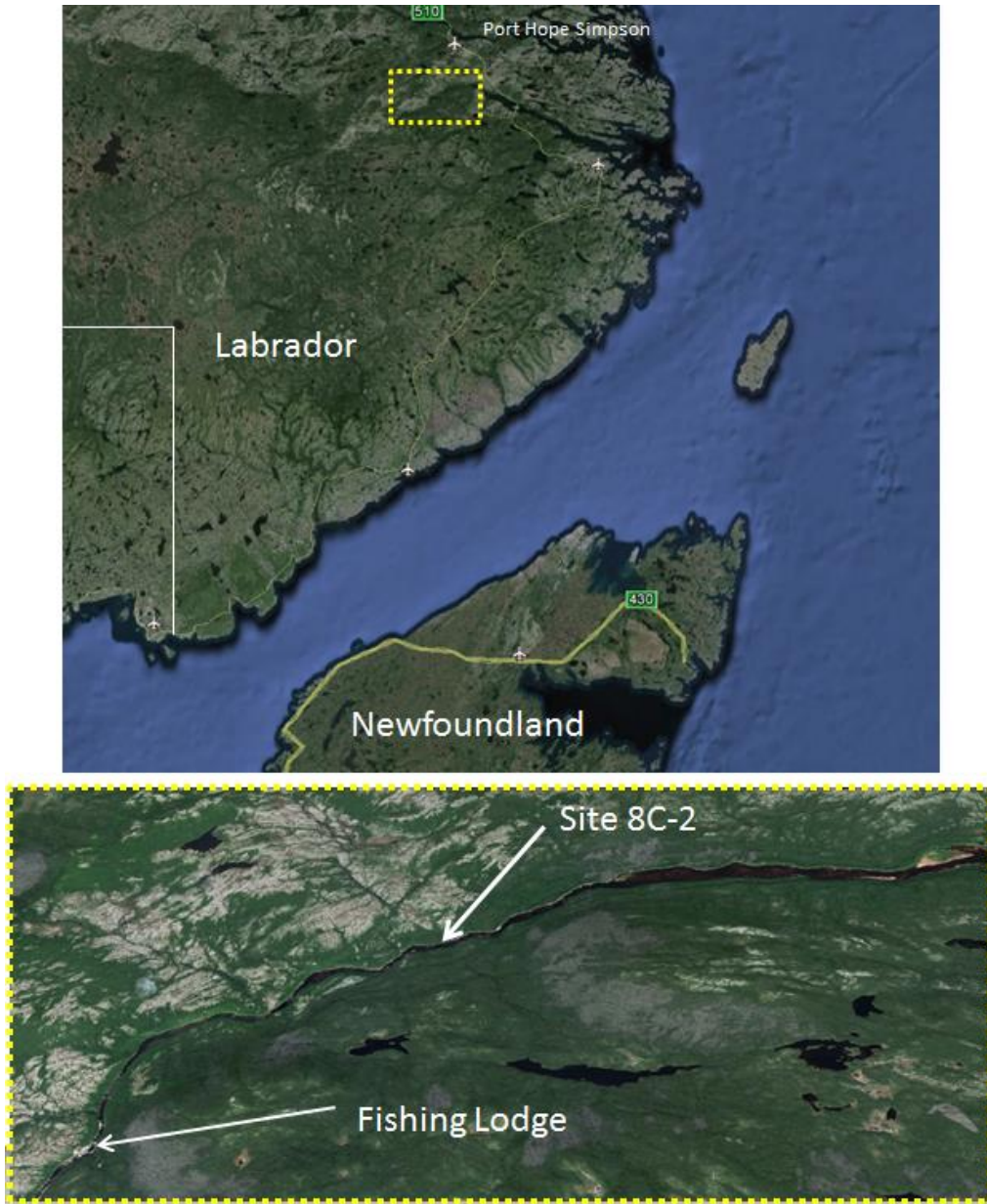

Figure 5: Location of Site 8C-2

1 **3.2 Mobile Generation Philosophy**

2 Hydro’s standard practice for mobile gensets has been to install them outside of a diesel generating
3 station as a short-term solution to address a capacity deficit following an unforeseen event such as
4 multiple¹⁷ unit failures, other plant emergency (e.g., fire), or sudden and unexpected load growth. With
5 the exception of summer peaking systems where units would exclusively operate in the summer
6 months, the installation of a mobile genset would be considered a temporary measure until a long-term
7 solution is established. This approach is considered industry common practice across Canada for utilities
8 operating in northern climates that experience harsh winter conditions with heavy snowfall. The
9 operation of mobile gensets in this environment has proven to be unreliable and has inherent safety and
10 environmental concerns. Hydro has firsthand experience operating mobile gensets¹⁸ and their
11 limitations as permanent sources of firm power. A list of the inadequacies associated with the
12 permanent operation of mobile gensets is presented in Table 3.

13 Addressing the deficiencies listed in Table 3 would require material capital investments for aspects
14 including a building structure with adequate space to properly shelter the mobile units and house the
15 mandatory auxiliary equipment. These are coupled with increased operating costs associated with
16 extensive revisions to current operating practices, as presented in Section 4.1. Such a solution would
17 also be absent of the benefits associated with the broader interconnection strategy for this region.

¹⁷ Diesel generating stations are designed to meet system demand following the loss of the largest unit.

¹⁸ There is one permanently installed mobile genset at both the Mary’s Harbour and L’Anse Au Loup Diesel Generating Stations. Prior to the fire at the Charlottetown Diesel Generating Station, the facility was equipped with two mobile gensets to supply firm power during the summer peak.

Table 3: Mobile Genset Deficiencies

Category	Deficiencies
Safety	<ul style="list-style-type: none"> • Limited Physical Space: Mobile enclosures have limited space which makes it physically demanding on operators to perform routine maintenance or operational checks. Operators are also in closer proximity to safety hazards. • Ambient Temperature: There is a potential for extreme cold or warm temperatures in the small mobile enclosures. This results in unacceptable working conditions for operators. • Noise: Mobile gensets can be a loud environment given their limited space and inability to dampen sound. • Lack of Fire Protection: Hydro’s mobile gensets are not equipped with fire protection systems. Additional sheltered space would be required to install a suitable fire suppression system. • Arc-Flash Hazards: The arc-flash boundaries associated with electrical equipment in the mobile genset extend beyond the mobile enclosure.¹⁹ Completely avoiding the arc-flash hazard could require an extended outage of the unit to de-energize the electrical equipment. A maintenance switch could be utilized to change the protection coordination and thereby reduce the arc-flash boundary but this introduces the possibility of more unnecessary unit trips potentially leading to customer outages. In normal operation, the arc-flash levels exceed that of any available arc-flash personal protective equipment (“PPE”), and while in “maintenance mode” PPE still may be required. This is not practical given the ambient temperature and limited space in the mobile enclosure.

¹⁹ The arc-flash boundary for Unit 2088 at Charlottetown is approximately 14 feet at minimum generation levels, reducing to 1.5 feet in maintenance mode.

Category	Deficiencies
Environment	<ul style="list-style-type: none"> • Additional Emissions Technology: It is expected that long-term operation will require more stringent control of emissions. Required technologies could include diesel particulate filters and more advanced emissions and Nitrogen Oxide (“NOx”) control equipment. NOx control system equipment for selective catalytic reduction and its associated storage for injection fluids could also require additional space. Mobile gensets would not have the necessary space to accommodate this equipment. • Lower Fuel Efficiency:²⁰ Mobile gensets have a greater station service requirement due to the lack of control over their auxiliary equipment (e.g., fuel pumps, radiator fans, etc.) and the electric heat requirements for offline units during winter months. • Less Renewable Energy Penetration: Mobile gensets have basic controls that are not designed for the optimization of renewable energy penetration. The necessary control infrastructure to maximize renewable penetration would require its own enclosure, given the lack of space inside the mobile genset. • Higher Probability of Fuel Spills: A site configuration with solely mobile units would be more prone to fuel spills. With an onboard fuel storage solution for each mobile genset (e.g., day tank), there are more points of failure. The prudent solution would be a metered fuel system with a common certified day tank in a dyke. Due to the limited space, mobile enclosures could not support the appropriate day tank configuration and the control panel and fuel pump would have to be installed in a separate building.
Reliability	<ul style="list-style-type: none"> • Winter Operation: Hydro has experienced the failure of mobile gensets due to the intake of snow during blizzard conditions. Without indoor installation of the mobiles, this remains a risk. Power cables running on the ground between units and on-site facilities are also subject to the freeze-thaw cycle which could adversely affect the integrity of the cables. In comparison to a diesel generating station, it would be difficult to provide the same level of reliability without situating mobile units in an enclosed building. Since the fire at the Charlottetown Diesel Generating Station, there have been some minor upgrades completed in an attempt to minimize these reliability concerns until the execution of long-term solution.²¹ • Limited Protection and Control: Mobile gensets have limited protection and controls and are, therefore, less reliable. • Lack of Condition Monitoring: Hydro’s existing mobile gensets lack adequate monitoring functionality and data is not retrieved and archived. The collection of operational data is essential for troubleshooting and planning purposes. • Reduced Reliability due to Adverse Conditions: The intense heat and vibration associated with a mobile genset makes them more susceptible to failures.

²⁰ Data shows an increased station service load at the Charlottetown Diesel Generating Station since the fire.

²¹ Please refer to proposal, “Charlottetown Diesel Generating Station Preparation for Winter Operation – Final Report,” Newfoundland and Labrador Hydro, March 9, 2020.

Category	Deficiencies
Operation and Maintenance (“O&M”)	<ul style="list-style-type: none"> • Increased Outages for Maintenance: Mobile gensets must be offline for some routine maintenance due to limited space in their enclosures. This increases the number and duration of unit outages. • Off-Site Maintenance: A significant amount of planned/unplanned maintenance or repair to a mobile unit would require relocation to the nearest suitable shop. This could be challenging depending on weather and road conditions. Mobile gensets are not easily transported and the disconnection process can be time consuming (e.g., fuel lines, service conductors, control wiring, fire hoses, exhaust stacks, radiators, etc.). Hydro also lacks the appropriate moving and transportation equipment in this region to accommodate the relocation of a unit. Any off-site work (e.g., overhauls) would likely prove more costly than on-site work. Due to the requirement for off-site work, mobile gensets must be road worthy, registered, and insured. • Reduced Productivity: Due to accessibility issues and other challenges, routine maintenance in a small mobile enclosure tends to be more time consuming and costly. • Winter Operation: The operation of multiple mobile units would be much more difficult during extreme winter conditions. Additional snow clearing would be required to ensure operators can navigate safely and quickly between units and on-site facilities. • Standardization: Mobile gensets tend to be more customized and utilize non-standard equipment/parts, which increases the requirement for training and vendor-performed maintenance. Non-standard parts may also be harder to obtain and additional stock would be required.

1 **3.3 Modularization**

2 A modular diesel plant is a design that is constructed off-site by a vendor and shipped to the
 3 construction site in modules for assembly. A modular unit is similar to a mobile genset in that it is
 4 transportable, but differs in that it is designed for a more permanent and scalable solution. Modular
 5 units are a more robust and enclosed option that is better equipped to operate in harsh climates.

6 The designs that were researched typically utilize construction containers (“C-Cans”) as the enclosure for
 7 the gensets to enable relocation. The on-site assembly follows the installation of a concrete pad, where
 8 the connection of each modular section takes approximately two weeks to install and commission.

9 The most common applications of this modular generation technology include the construction, mining,
 10 and power generation industries. The estimated cost of a modular plant to replace the Charlottetown
 11 Diesel Generating Station would be in excess of \$20 million. However, the life cycle of modular plants

1 are unknown at this time and are not expected to be as long as a proven diesel plant installation.
2 Furthermore, the application of this technology in the power generation industry has not included any
3 permanent installations in northern climatic regions such as the south coast of Labrador.

4 The main advantage of a modular plant is that is scalable and capacity additions or replacements can be
5 performed in a relatively short period of time. This feature is ideal for industries such as the mining and
6 construction, since it is common for these activities to be conducted for a limited time in remote
7 locations without access to a grid power. A modular plant can be installed anywhere and can be
8 removed quickly and sent to another location. The power generation industry generally uses these
9 plants for backup power purposes, with only one known prime power application in Canada. However,
10 this prime power plant is located in British Columbia which experiences milder winter weather in
11 comparison to southern Labrador.

12 In summary, there is a lack of industry experience operating modular plants in harsh northern climates
13 that experience significant snowfall and there is uncertainty with respect to their expected life cycles in
14 this environment. Given these considerations and the similar upfront capital costs to a traditional diesel
15 plant, modular plant installations are currently not a viable alternative to address Charlottetown's future
16 supply needs.

17 **3.4 Diesel Generating Station Replacements**

18 The timing of a diesel generating station replacement depends heavily on the existing condition and
19 design capacity of the facility. Hydro has established a replacement schedule (Table 4) for the diesel
20 generating stations in southern Labrador based on service life, plant capacity, and condition. The diesel
21 generating stations in Mary's Harbour and Port Hope Simpson have both exceeded their design plant
22 capacity and any future generation expansion would likely require a new plant or extension.

Table 4: Diesel Generating Station Replacement Schedule

Location	In-Service Year	Replacement Year (Projected)
Mary's Harbour	1994	2030
Port Hope Simpson	1995	2035
St. Lewis	2006	2045

1 **3.5 Operations and Maintenance and Fuel Costs**

2 There are currently four diesel generating stations operating in the southern Labrador region and based
3 on economies of scale it would suggest that it could be more economically feasible to minimize the
4 number of facilities. A reduction in the number of diesel generating stations would inherently decrease
5 the overall operating and maintenance costs in the region.

6 Hydro forecasts that the total annual O&M cost for all four diesel generating stations would be
7 approximately \$2.15 million²² per year over the 50-year duration of the study. Hydro estimates that by
8 supplying southern Labrador with one centralized diesel generating station, the overall O&M costs
9 would reduce by approximately \$670,000 per year.

10 Hydro anticipates that the replacement of four diesel generating stations with one larger centralized
11 diesel generation station would be much more fuel efficient, since it would reduce the overall dispatch
12 requirement for diesel gensets. It is estimated that supplying southern Labrador with one centralized
13 diesel generating station would reduce the amount of diesel fuel consumed by approximately 600,000
14 L²³ per year.

15 Diesel fuel consumption can also be offset through the implementation of energy efficiency initiatives.
16 The construction of a new diesel generating station provides a greater opportunity to implement energy
17 efficiency initiatives within the facility. The following initiatives would be considered during the detailed
18 design phase for the construction of any new diesel generating station:

- 19 • Waste Heat Recovery: Use the thermal energy produced by the diesel gensets to supply heating
20 for the diesel generating station or customers in the area.
- 21 • Unit Sizing: Properly sizing diesel units in a diesel generating station can improve overall plant
22 efficiency by optimizing the number of diesel units in operation at one time and minimize
23 operating hours. This would also reduce the number unit overhauls and replacements through
24 the life expectancy of the diesel generating station.
- 25 • Unit Efficiency: Purchase newer diesel units that are more efficient.
- 26 • Variable Frequency Drives (“VFD”): Installing VFDs on station service motors.

²² Average projected annual cost from 2023 to 2070 (\$2020). Including overhaul costs, but excluding fuel costs.

²³ Average projected annual consumption from 2024 to 2070 (\$2020). This translates into approximately \$700,000 per year based on Hydro’s baseline fuel price forecast.

- 1 • Reduce Station Service Load: Perform more traditional energy efficiency initiatives to reduce
2 station service load (e.g., LED²⁴ lights, motion sensors, timers, dimmers, improve building
3 insulation, etc.).
- 4 • Reduce Power Losses (I^2R) on the System's Distribution Lines and Equipment:
 - 5 ○ Voltage conversion;
 - 6 ○ Install more efficient transformers with lower power losses (load/no-load); and
 - 7 ○ Increase conductor sizes.

8 **3.6 Consideration for Renewable Energy Integration**

9 The scope of this study focuses on the development of firm supply solutions for Charlottetown, with
10 consideration of regional supply for neighbouring communities. As indicated in Appendix B, Hydro does
11 not consider wind, solar, or run-of-river hydro generation²⁵ as firm supply solutions. Renewable energy
12 sources such as wind and solar installed in isolated systems are considered non-firm energy sources due
13 to their intermittent nature.

14 Energy storage technologies have not yet matured to the point that they are a viable alternative for
15 firm, reliable, least-cost provision of power when compared to diesel generation. This is supported by a
16 National Renewable Energy Laboratory (“NREL”) report “2018 U.S. Utility-Scale Photovoltaics-Plus-
17 Energy Storage System Costs Benchmark.”²⁶ This report includes a comparison of average energy
18 storage durations for such systems and indicates that most storage technology is limited to 10 hours in
19 duration, where none of which exceed an average of 100 hours.

20 For Hydro to rely on wind, solar, or run-of-river hydro generation, energy storage technologies would
21 need to bridge the prolonged time in which there is little exposure to these energy sources. These
22 periods may extend for several days; therefore, energy storage solutions are not a viable option. As
23 such, Hydro cannot consider wind and solar generation as a firm energy solution for southern Labrador.

²⁴ Light-emitting diode (“LED”).

²⁵ Hydroelectric plants with larger storage reservoirs would provide firm capacity to the system; however, the amount of capacity would be dependent on the particular site and the design of the plant.

²⁶ Ran Fu, Timothy Remo, and Robert Margolis, “2018 U.S. Utility Scale Photovoltaics-Plus-Energy Storage System Costs Benchmark,” National Renewable Energy Laboratory, November 2018, <<https://www.nrel.gov/docs/fy19osti/71714.pdf>>.

1 While renewable energy sources in their current state are not viable for the provision of firm capacity,
2 these sources can be used to supply energy to offset diesel fuel consumption and thereby reduce
3 operating costs. Preliminary analysis was performed to assess the potential for fuel displacement for a
4 single regional generating station in comparison to the status quo and is provided in Appendix B. As
5 presented in Appendix B, a regional diesel generating station solution would allow for more renewable
6 energy penetration in southern Labrador and, therefore, has the potential to offset more fuel
7 consumption in the future.

8 **3.7 Reliability Assessment**

9 Hydro expects that there would be an overall improvement in system reliability with a southern
10 Labrador interconnection. Appendix C quantifies the improvement to system reliability.

11 **3.8 Motor Starting – Voltage Flicker**

12 Hydro's isolated distribution systems are typically supplied from one source, a diesel generating station
13 with three to six gensets. These systems naturally do not have an abundance of available fault energy as
14 they are not connected to a large electrical grid; therefore, the amount of available fault current on a
15 diesel system is limited and restricted by the size and number of diesel gensets. Consequently, it can be
16 a challenge for these isolated distribution systems to start a large customer motor without impacting
17 other customers. Contributing to the situation is the fact that most of Hydro's isolated distribution
18 systems operate at a low distribution voltage of 4.16 kV. When large motors are connected to any
19 distribution system, Hydro provides the customer with a list of criteria they must meet in order for their
20 motor to not have an adverse effect on their other customers.

21 There are two seafood processing plants in the southern Labrador region that require relatively large
22 motors for their operation. The diesel generating stations in Charlottetown and Mary's Harbour are
23 equipped with large motors that are responsible for driving compressors. In Charlottetown there have
24 been some reports of voltage flicker caused by the starting of the shrimp processing plant's 250 hp
25 motor.

26 With an electrical interconnection and the 25 kV voltage conversion of southern Labrador distribution
27 systems, the fault levels on these systems will increase as shown in Table 5, therefore minimizing the
28 effect of voltage flicker during motor starting.

Table 5: 3-Phase Fault Levels (Before/After Interconnection)

System	3-Phase Fault Levels at Proposed Points of Interconnection (MVA)		Percent Increase (%)
	Status Quo	After Interconnection	
Charlottetown	3.94	7.69	195%
Mary's Harbour	3.45	7.52	218%
Port Hope Simpson	2.64	9.98	378%
St. Lewis	2.68	7.52	281%

3.9 Low Voltage Conditions

All the distribution systems in southern Labrador are currently operating within acceptable voltage levels. Load flow analysis indicates that unforeseen load growth within the Charlottetown and Mary's Harbour distribution systems would require system upgrades to avoid abnormal voltage conditions. A 25 kV interconnection and voltage conversion in southern Labrador would significantly improve the voltage levels and accommodate future community development.

4.0 Summary of Technically Viable Alternatives

This section will provide a description of all the technically viable alternatives that were considered for this study. All alternatives were designed to adhere to the Rural Planning Standard provided in Appendix D. The following are the alternatives that were assessed from a technical perspective:

- Alternative 1: Continued Operation of Mobile Gensets;
- Alternative 2: New Diesel Generating Station in Charlottetown;
- Alternative 3a: Southern Labrador Interconnection – Phased Approach;
- Alternative 3b: Southern Labrador Interconnection – Full Interconnection;
- Alternative 4: Interconnection to the Labrador Interconnected System; and
- Alternative 5: Interconnection with Hydro Generation (Site 5B/Site 8C-2).

4.1 Alternative 1: Continued Operation of Mobile Gensets

This alternative would involve the continued operation of mobile gensets with the purpose of supplying power to the community of Charlottetown and surrounding areas. As discussed in Section 3.2, there are concerns associated with the existing arrangement at the Charlottetown Diesel Generating Station

1 which is comprised of three²⁷ mobile gensets situated outside that are exposed to the harsh southern
2 Labrador climate. This temporary configuration would require additional capital upgrades to address the
3 deficiencies outlined in Table 3 (Section 3.2) and ensure reliable long-term operation. Please refer to
4 Appendix E for a single-line diagram for the existing Charlottetown Diesel Generating Station with
5 mobile generation, which is an appropriate representation for this alternative.²⁸ The following are
6 further details relating to the scope of this alternative:

- 7 • The construction of a 4,400 ft² steel building enclosure with a concrete foundation that would
8 be equipped with the necessary ventilation, lighting, and fire suppression systems. The building
9 would consist of a bathroom, lunchroom, office, electrical room, control room, battery room,
10 workshop, and an area allocated for a fire suppression system.
- 11 • The engine hall would have adequate space to accommodate four 1,000 kW diesel units
12 including provisions for future load growth. The three existing mobile gensets on site would be
13 relocated and permanently installed in this new engine hall. These three gensets provide
14 enough generation capacity to meet current forecasted peak demand.
- 15 • Each unit would be equipped with a day tank, which would be supplied by the existing bulk
16 storage tanks.
- 17 • The station service requirement would be 600A. A motor control centre (“MCC”) would be
18 installed for the remote radiators, intake/exhaust fans, fuel coolers, fuel pumps and any other
19 motor auxiliary load.
- 20 • The installation of an overhead crane to support maintenance activities.
- 21 • The other diesel generating stations in the region would eventually be replaced as per Table 4 in
22 Section 3.4 and constructed in their existing location and their fuel storage tanks would be
23 salvaged.

24 **4.2 Alternative 2: New Diesel Generating Station in Charlottetown**

25 This alternative would involve the construction of a new diesel generating station in Charlottetown at a
26 new location. Each community in southern Labrador would remain electrically isolated for the
27 foreseeable future and rely on its respective diesel generating station to provide a reliable source of

²⁷ Two 910 kW and one 725 kW.

²⁸ The only significant difference being the station service requirement would be 600 A to support the increased auxiliary load.

1 electricity. Please refer to Appendix E for a single-line diagram representing this alternative. The
2 following are further details relating to the scope of this alternative:

- 3 • The construction of a 5,900 ft² steel building enclosure with a concrete foundation, equipped
4 with the necessary ventilation, lighting, and fire suppression systems. The building would consist
5 of a bathroom, lunchroom, office, electrical room, control room, battery room, workshop, and
6 an area allocated for a fire suppression system. There would be a requirement for the purchase
7 of land²⁹ and the necessary site work, including fencing.
- 8 • The engine hall would have adequate space to accommodate five 1,000 kW diesel units
9 including provisions for future load growth. There would be four units initially installed to
10 provide enough generation capacity to meet current forecasted peak demand. Each unit would
11 meet the following specifications:
 - 12 ○ Unit Speed: 1,200 rpm;
 - 13 ○ Terminal Voltage: 4.16 kV;
 - 14 ○ Unit Ratings:³⁰ 600 kW, 800 kW, and two 1,000 kW; and
 - 15 ○ Each unit would be equipped with a dedicated radiator.
- 16 • The diesel generating station would be equipped with a day tank, which would be supplied by
17 new bulk storage (300,000 L).
- 18 • The station service requirement would be 600 A. An MCC would be installed in the control room
19 to supply remote radiators, intake/exhaust fans, fuel coolers, fuel pumps, and any other motor
20 auxiliary load.
- 21 • The installation of an overhead crane to support maintenance activities.
- 22 • The removal and decommissioning of the existing Charlottetown Diesel Generation Station. The
23 existing mobile gensets would be available to support Hydro's operation in the region and could
24 be deployed for peaking or during an emergency event (e.g., plant fire).

²⁹ The site of the new diesel generating station would be established during the detailed design phase.

³⁰ Sizes were approximated as there are differences in the actual capacities of generating units available from various manufacturers. Actual capacities will be confirmed during the gen set procurement process. This note applies to all new genset sizes referenced in this document.

- 1 • The installation of a 4.16 kV switchgear to accommodate five 1,000 kW units. Hydro’s standard
- 2 micro-controllers are designed with provisions for future integration of renewable generation.
- 3 • The construction of a second dedicated 4.16 kV distribution feeder to supply the shrimp
- 4 processing plant.
- 5 • Installation of two reclosers at the diesel generating station to accommodate two distribution
- 6 feeders.
- 7 • The other diesel generating stations in the region would eventually be replaced as per Table 4 in
- 8 Section 3.4 and constructed in their existing location with their fuel storage tanks being
- 9 salvaged.

4.3 Alternative 3a: Southern Labrador Interconnection – Phased Approach

This alternative consists of a phased approach to a southern Labrador interconnection, with the initial phase including the construction of a regional diesel generating station in Port Hope Simpson and a 25 kV interconnection to the Port Hope Simpson and Charlottetown distribution systems. A brief summary of the initial and subsequent two phases of this alternative is provided in Table 6. Figure 6 is a visual representation of the construction phases superimposed on a map of southern Labrador. Please refer to Appendix E for a single-line diagram representing this alternative.

Table 6: Alternative 3a – Phased Approach

Phase	Description	Year	Diesel Scope	Distribution Scope
1	Construct regional diesel generating station in PHS Interconnect CHT/PHS to regional diesel generating station	2023	Four units initially installed: <ul style="list-style-type: none"> • One 800 kW • Two 1,500 kW • One 1,000 kW 	<ul style="list-style-type: none"> • Construct 53 kilometres of 25 kV line • 25 kV voltage conversion (CHT/PHS) • Install one set of 200 A voltage regulators
2	Interconnect MSH to regional diesel generating station	2030	Fifth unit installed (1,800 kW)	<ul style="list-style-type: none"> • Construct 50 kilometres of 25 kV line • 25 kV Voltage conversion (MSH) • Install one set of 200 A voltage regulators
3	Interconnect SLE to regional diesel generating station	2045	N/A	<ul style="list-style-type: none"> • 30 kilometres of 25 kV line • 25 kV voltage conversion (SLE)

1 The following are additional details associated with Phase 1 of this alternative:

2 • Specific details on the design of the regional diesel generating station in Port Hope Simpson are
3 as follows:

4 ○ The construction of an 8,800 ft² steel building enclosure with a concrete foundation and
5 would be equipped with the necessary ventilation, lighting, and fire suppression systems.
6 The building would consist of a bathroom, lunchroom, office, electrical room, control room,
7 battery room, workshop, and an area allocated for a fire suppression system. There would
8 be a requirement for the purchase of land and the necessary site work including fencing.

9 ○ The engine hall would have adequate space to accommodate six 2,000 kW class diesel units.
10 Generation capacity was optimized on the basis of the reliability analysis outlined in
11 Appendix C. There would be four units initially installed to provide enough generation
12 capacity to meet the current forecasted peak demand of Charlottetown and Port Hope
13 Simpson. Each unit would meet the following specifications:

- 14 ■ Unit Speed: 1,200 rpm;
- 15 ■ Terminal Voltage: 4.16 kV;
- 16 ■ Unit Ratings: 1,000 kW, 1,500 kW, 1,800 kW; and
- 17 ■ Each unit would be equipped with a dedicated radiator.

18 ○ The installation of two 5 MVA, 4.16 kV/25 kV power transformers to meet N-1 Firm
19 Transformation Capacity as per the Rural Planning Standard (Appendix D). The transformers
20 would be equipped with on-load tap changers.

21 ○ The plant would be equipped with a day tank, which would be supplied by new bulk storage
22 (approximately 400,000 L).

23 ○ The station service requirement would be 600 A. An MCC would be installed in the control
24 room to supply remote radiators, intake/exhaust fans, fuel coolers, fuel pumps, and any
25 other motor auxiliary load.

26 ○ The installation of an overhead crane to support maintenance activities.

27 ○ The removal and decommissioning of the existing Charlottetown and Port Hope Simpson
28 Diesel Generating Stations. The existing mobile gensets would be available in support of

1 Hydro's operation in the region and could be deployed for peaking, during an emergency
2 event (e.g., plant fire), or during planned capital work.

- 3 • Specific details on the design of the 25 kV interconnection are as follows:

- 4 ○ The construction of two new 25 kV distribution lines to 66 kV standards as shown in Figure
5 6:

- 6 ■ A 50 kilometre line along highway routes 510 and 514 between the new regional diesel
7 generating station in Port Hope Simpson and Charlottetown. The new line would be
8 comprised of 477 ASC conductors. A fibre-optic line would also be installed for
9 communication purposes.

- 10 ■ A 3 kilometre line between the new regional diesel generating station in Port Hope
11 Simpson and the Port Hope Simpson distribution system. The new line would be
12 comprised of 477 ASC conductors.

- 13 ○ The installation of two reclosers on the two 25 kV lines feeding Charlottetown and Port Hope
14 Simpson distribution systems. There would be provisions for another recloser for the future
15 phases of the interconnection.

- 16 ○ A 25 kV voltage conversion of the Charlottetown and Port Hope Simpson distribution
17 systems. This is a requirement for motor starting as discussed in Section 3.8.

- 18 ○ The installation of a set of 200 A voltage regulators as shown in Appendix E.

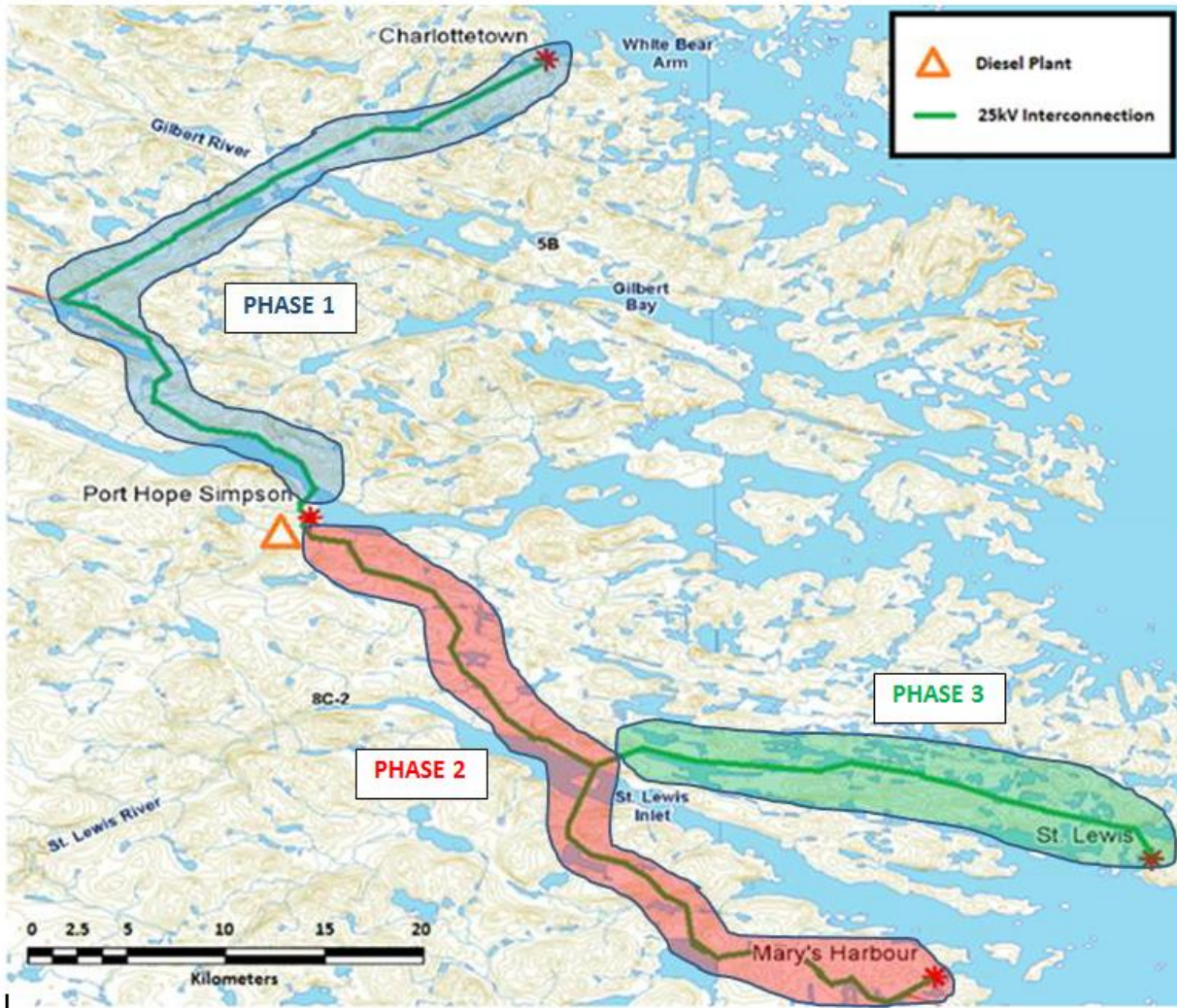

Figure 6: Southern Labrador Interconnection – Phased Approach

4.4 Alternative 3b: Full Interconnection of Southern Labrador

This alternative consists of the entire 25 kV interconnection of southern Labrador by the year 2024 as in Figure 7, including the full construction of a regional diesel generating station in Port Hope Simpson. Refer to Appendix E for a single-line diagram for this alternative. The following are additional details associated with this alternative that differ from Alternative 3a:

- Specific details on the design of the regional diesel generating station in Port Hope Simpson are as follows:
 - There would be five units initially installed to provide enough generation capacity to meet current forecasted peak demand of Charlottetown, Mary's Harbour, Port Hope Simpson, and St. Lewis.
 - The removal and decommissioning of the Charlottetown, Mary's Harbour, Port Hope Simpson, and St. Lewis Diesel Generation Stations. The existing mobile gensets would be available to support Hydro's operation in the region and could be deployed for peaking, during an emergency event, or during planned capital work.
- Specific details on the design of the 25 kV interconnection are as follows:
 - The construction of the following 25 kV distribution lines to 66 kV standards as shown in Figure 7:
 - A 50 kilometre line along highway routes 510 and 514 between the new regional diesel generating station in Port Hope Simpson and Charlottetown. The new line would be comprised of 477 ASC conductors. A fibre-optic line would also be installed for communication purposes.
 - A 3 kilometre line between the new regional diesel generating station in Port Hope Simpson and the Port Hope Simpson distribution system. The new line would be comprised of 477 ASC conductors.
 - A total of 80 kilometres of line to connect Mary's Harbour and St. Lewis to the new regional diesel generating station in Port Hope Simpson. The new line would be comprised of 477 ASC conductors. A fibre optic line would also be installed for communication purposes
 - The installation of three reclosers to support a 25 kV interconnection.

- 1 ○ A 25 kV voltage conversion of the Charlottetown, Mary's Harbour, Port Hope Simpson, and
- 2 St. Lewis distribution system. This is a requirement for motor starting as discussed in Section
- 3 3.8.
- 4 ○ The installation of two sets of 200 A voltage regulators as shown in Appendix E.



Figure 7: Southern Labrador Interconnection – Full Interconnection

5 **4.5 Alternative 4: Interconnection to the Labrador Interconnected System**

6 This alternative consists of the 25 kV interconnection of southern Labrador to the Labrador
7 Interconnected System near Happy Valley-Goose Bay. This would involve the construction of

1 approximately 400 kilometres of 138 kV transmission line. This new 138 kV line would tap off the
2 existing 138 kV line between Muskrat Falls Terminal Station #3 and the Happy Valley Terminal Station. A
3 new terminal station would have to be constructed in Port Hope Simpson to step the voltage down to 25
4 kV. A 25 kV interconnection would then be required to distribute the power from Port Hope Simpson to
5 the other isolated systems in the area.

6 Preliminary high-level estimates prepared by Hydro indicates that the total capital cost of such an
7 interconnection would be in excess of \$400 million³¹ and due to the magnitude of this cost it was not
8 considered for the economic analysis outlined in Section 5.0.

9 **4.6 Alternative 5: Interconnection with Hydro Generation**

10 This option would include the development of two small-scale hydro plants, one on the Gilbert River
11 (Site 5B) with storage and one run-of-river plant on the St. Lewis River (Site 8C-2) as described in Section
12 3.1. The existing Port Hope Simpson and St. Lewis Diesel Generating Stations would still be required and
13 remain operational for backup and peaking purposes, since the available firm generation from both
14 hydro sites would not satisfy the forecasted power requirements for all four communities during the
15 winter months.

16 These two hydroelectric developments and the four communities would be interconnected to form an
17 isolated grid with a standard distribution line voltage of 25 kV. This interconnection would require
18 approximately 150 kilometres of distribution line carrying 477 kcmil ASC conductors. Due to the length
19 of these lines and the distribution of electrical load, two bi-directional voltage regulators would be
20 required for additional voltage support. The configuration of this interconnection is superimposed on a
21 map of Labrador and is shown in Figure 2 in Section 3.1.

22 This alternative is technically a viable option, but as discussed in detail in Section 3.1, the environmental
23 impacts accompanying these two hydro sites would require significant mitigation. The total capital cost
24 associated with two hydro developments and a 25 kV interconnection, including environmental
25 mitigation considers, was determined to be in the range of \$160 million to \$210 million. These costs do
26 not include operational considerations for these facilities nor for the continued operation and
27 maintenance requirement for the St. Lewis and Port Hope Simpson Diesel Generating Stations. In

³¹ This does not include O&M costs, power purchases, or costs associated with potential generation expansion.

1 consideration of the details provided above and the values presented in the economic evaluation in
2 Section 5.0, this alternative was screened from further consideration.

3 **5.0 Economic Evaluation of Alternatives**

4 The economic analysis outlined in this Section provides a comparison of the cumulative present worth
5 (“CPW”) of each selected alternative to determine the least-cost option over a study period of 50 years.
6 The discount rate used in the study is 5.65% which reflects Hydro’s current long-term weighted average
7 cost of capital. The economic analysis for this study considered the base case forecast for load and fuel
8 prices which are provide in Appendices A and F, respectively. The inputs into the CPW analysis for each
9 option are as follows:

- 10 • Cost estimates:
 - 11 ○ Capital costs;
 - 12 ○ O&M costs;
 - 13 ○ Overhaul costs;
 - 14 ○ Asset replacements; and
 - 15 ○ Diesel generating station removal/decommissioning costs;
- 16 • Operating Energy and Demand Forecast (kW)(see Appendix A);
- 17 • Diesel Fuel Prices (see Appendix F); and
- 18 • Remaining net book values of major assets.

19 **5.1 Alternatives**

20 The following alternatives were selected as economically and environmentally viable options to be
21 evaluated as part of the economic analysis:

- 22 • Alternative 1: Continued Operation of Mobile Gensets;
- 23 • Alternative 2: New Diesel Generating Station in Charlottetown;
- 24 • Alternative 3a: Southern Labrador Interconnection – Phased Approach; and
- 25 • Alternative 3b: Southern Labrador Interconnection – Full Interconnection.

- 1 Table 7 provides a summary of the estimated capital costs associated with every phase of each
 2 alternative. The cost estimates were classified as AACE Class 5 level estimates for screening purposes.

Table 7: Major Capital Cost Summary³²

Alternative	Project Phase	In-Service Year	Capital Costs (\$2020)
1	CHT Upgrades	2023	\$10,400,000
	MSH Diesel Generating Station Replacement	2030	\$18,900,000
	PHS Diesel Generating Station Replacement	2035	\$17,000,000
	SLE Diesel General Station Replacement	2045	\$14,200,000
	Total		\$60,600,000
2	CHT Diesel Generating Station Replacement	2024	\$21,400,000
	MSH Diesel Generating Station Replacement	2030	\$18,900,000
	PHS Diesel Generating Station Replacement	2035	\$17,000,000
	SLE Lewis Diesel General Station Replacement	2045	\$14,200,000
	Total		\$71,500,000
3a	Phase 1	2024	\$39,400,000
	Phase 2	2030	\$14,400,000
	Phase 3	2045	\$6,700,000
	Total		\$60,500,000
3b	-	2024	\$63,900,000
4	-	2025	> \$400,000,000
5	-	2025	> \$160,000,000

3 **5.2 Study Assumptions**

4 This section provides a brief overview of some of the assumptions as it relates to the key inputs into the
 5 CPW analysis:

6 **5.2.1 Capital Costs**

- 7
 - All capital cost estimates were developed by Hydro based on the following assumptions:
- 8
 - A 10% contingency was applied to each direct cost estimate to account for uncertainty and
- 9 risk exposure.
- 10
 - 4.875% Interest during Construction.
- 11
 - Taxes were not included.

³² Alternatives 4 and 5 were removed from consideration on the basis of capital costs, as discussed in Section 4.5 and 4.6, respectively.

- 1 • Each project phase was assumed to be completed by the end of the in-service year.
- 2 • Diesel genset replacements were developed using historical costs and the most recent genset
- 3 costs provided by vendors.
- 4 • Future diesel generating station replacements were assumed to cost a percentage of the
- 5 estimated cost for a new diesel generating station in Charlottetown (Alternative 2) based on
- 6 plant size.
- 7 • All diesel generating station replacements, with the exception of Charlottetown, were assumed
- 8 to be constructed in their existing location. The current Charlottetown site has limited physical
- 9 space and likely would not support a new diesel generating station.

10 **5.2.2 O&M and Overhaul Costs**

- 11 • The annual O&M costs for existing diesel generating stations were based on historical actual
- 12 costs (five-year average).
- 13 • The annual O&M costs for new diesel generating stations were developed based on information
- 14 provided by Hatch in 2013.
- 15 • The annual O&M costs for the 25 kV interconnection accounted for vegetation control, pole
- 16 replacements, infrared inspections, as well preventative maintenance for gang-operated
- 17 switches, and distribution voltage regulators.
- 18 • All diesel genset overhaul cost estimates were developed based on actual costs from previously
- 19 performed overhauls.

20 **5.2.3 Depreciation**

- 21 • For Hydro’s purposes the depreciable life is considered to be the estimated service life. Table 8
- 22 lists the depreciable life of the major assets associated with the proposed alternatives.

Table 8: Depreciable Life of Assets

Asset	Depreciable Life (Years)
Diesel Gensets	25
Diesel Generating Stations	40
25 kV Interconnection	40
Fuel Tanks	30

- 1 • The straight-line depreciation method was applied, which assumes a constant rate of
- 2 depreciation for each major asset.
- 3 • Any asset currently in-service that was replaced during the study was assumed to have no
- 4 salvage value.
- 5 • Any new asset added during the study period was assumed to have no salvage value at the end
- 6 of the study (2070).

7 5.2.4 Asset Replacement/Overhaul Schedules

8 A diesel generating station replacement depends heavily on the existing condition and capacity of the
 9 plant. Based on service life, plant capacity, and condition, Hydro has established a replacement schedule
 10 for the diesel generating stations in southern Labrador which is outlined in Table 9.

Table 9: Projected Replacement Years

Diesel Generating Station	Projected Replacement Year
Mary’s Harbour	2030
Port Hope Simpson	2035
St. Lewis	2045

11 The frequency of diesel genset replacements and overhauls are based on operating hours, which varies
 12 depending on the rated speed of the unit, as shown in Table 10. The projected operating hours for every
 13 unit in each alternative was derived using load profiles and forecasts.

Table 10: Diesel Genset Replacement/Overhaul Frequency

Unit Speed (rpm)	Replacement (Hours of Operation)	Overhaul (Hours of Operation)
1,800	100,000	20,000
1,200	120,000	30,000

14 5.2.5 Fuel Consumption

15 The efficiency of existing diesel generating stations was determined based on historical energy and fuel
 16 consumption data and is provided in Table 11.

Table 11: Diesel Generating Station Efficiencies

Diesel Generating Station	Efficiency (kWh/L)
Charlottetown	3.42
Mary's Harbour	3.32
Port Hope Simpson	3.48
St. Lewis	3.55

- 1 • A 5% increase in fuel efficiency was assumed for each new diesel generating station
- 2 replacement. The construction of a new diesel generating station would inherently make it more
- 3 cost effective to implement energy efficiency initiatives.
- 4 • The plant efficiency for the regional diesel generating station was assumed to be 3.75 kWh/L.
- 5 • The assumptions relating to fuel price forecast are provided in Appendix F.
- 6 • Energy forecasts were developed by Hydro and their assumptions are provided in Appendix A.
- 7 • The station service energy requirement for each existing diesel generating was provided as part
- 8 of the Operating Load Forecast.³³ The new regional diesel generating station was assumed to
- 9 have an annual station service energy requirement of 450 MWh per year.
- 10 • Load flow analysis was performed to determine the power losses for each alternative.
- 11 • Carbon taxes were omitted in the base case analysis but included in the sensitivity analysis.
- 12 • Renewable energy penetration to offset diesel fuel consumption was not considered in the base
- 13 case analysis but included in the sensitivity analysis.

14 **5.3 Study Results**

15 The CPW for each alternative and its variance from the least-cost alternative are summarized in Table
 16 12. As indicated, interconnected solutions are demonstrated to have the lowest CPW. Alternative 3a is
 17 the least-cost option over Alternative 3b with a CPW difference of approximately \$1,900,000. This
 18 difference is considered marginal given the magnitude of total CPW for each alternative and the
 19 accuracy range of the Class 5 estimates. A slight change to the capital or operating costs of either
 20 alternative could alter the results of the CPW analysis, as discussed in Section 6.0. The primary reason
 21 the interconnection options (Alternatives 3a/3b) have a substantially lower CPW than the other

³³ The difference between gross (kWh) and net (kWh).

1 alternatives is due to the elimination of the requirement to construct three future diesel generating
 2 stations, along with a significant reduction in operating costs.

Table 12: CPW Analysis Results (2020–2070) – 50-Year Study (\$)³⁴

Alternative	CPW	CPW Difference between Alternative and the Least-Cost Alternative
3a: Phased Interconnection	153,400,000	0
3b: Full Interconnection	155,300,000	1,900,000
1: Mobile Option	177,400,000	24,000,000
2: New CHT Diesel Generating Station	184,700,000	31,200,000

3 Figure 8 is a graph of the CPW for each alternative from the year 2020 to 2070. The crossover year is
 4 about 2035 (12 years) between Alternative 1 and the two alternatives involving a southern Labrador
 5 interconnection. The graph shows the CPW impacts for each alternative over the 50 years and illustrates
 6 the impacts of various milestones throughout the study period. The large step changes in each plot are
 7 caused by large capital investments, which would be either a diesel generating station replacement or a
 8 phase of a project. Alternative 3b has the largest step change in 2024, which is the \$63.9 million upfront
 9 capital cost associated with the full 25 kV interconnection and the regional diesel generating station. The
 10 slope of each plot is a function of operating costs, where a steeper slope represents higher operating
 11 costs. The alternatives with more diesel generating stations in-service have a steeper slope, as they
 12 require more annual O&M and fuel costs. Although Alternative 3b has the highest upfront capital cost, it
 13 has the lowest annual operating costs (flatter slope) in comparison to the other alternatives. Alternative
 14 3b also has less capital investment throughout the remainder of the 50-year study.

15 A summary of the reduction of operating costs for each alternative in relation to Alternative 1 is
 16 provided in Table 13. The table indicates a significant reduction in operational costs when diesel
 17 generating stations are substituted with an interconnection.

³⁴ CPW is presented in 2020 dollars.

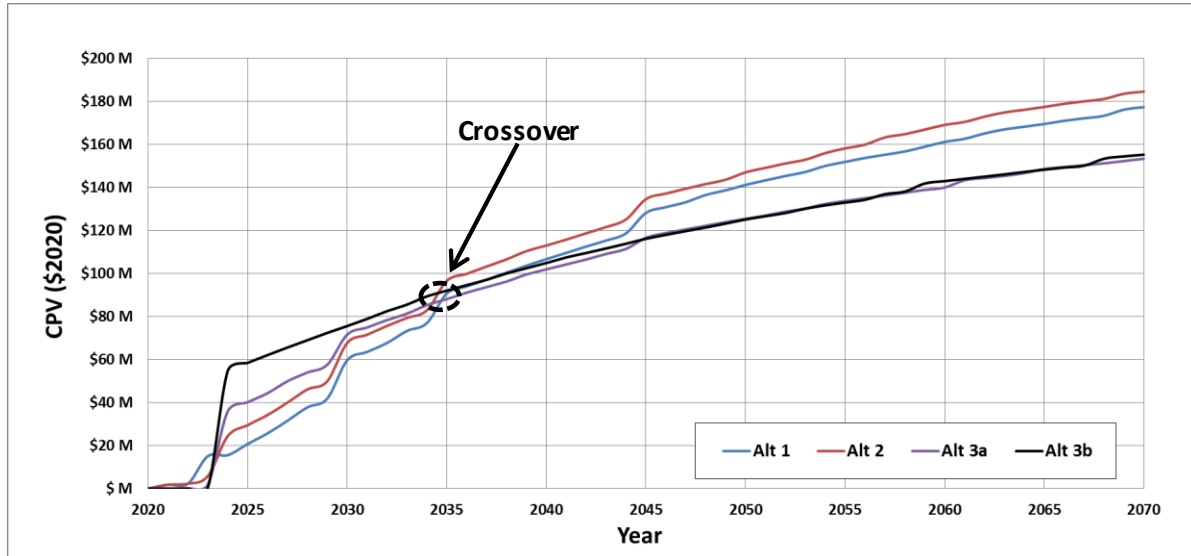

Figure 8: CPW Plots of Alternatives

Table 13: Operating Cost Comparison of Alternatives³⁵

Alternative	Year	New 25kV Line Constructed (km)	Diesel Generating Station In-Service	Capital Costs (\$millions)	Average Reduction in Fuel Costs (\$millions/yr) ³⁶	Average Reduction in O&M Costs (\$millions/yr) ^{37,38}	Average Total Reduction in Operating Cost (\$millions/yr) ³⁹
1	2023–2070	0	4	10.4	-	-	-
2	2023–2070	0	4	21.4	0.11	0.05	0.16
3a	2023–2030	53	3	39.4	0.20	0.47	0.66
	2031–2045	50	2	14.4	0.49	0.69	1.18
	2046–2070	30	1	6.7	0.78	1.89	2.67
3b	2023–2070	133	1	63.9	2.16	1.21	3.36

³⁵ All costs are in 2020 dollars.

³⁶ Alternative 1 (Continued mobile unit operation) is used as the reference.

³⁷ Alternative 1 (Continued mobile unit operation) is used as the reference.

³⁸ Including overhaul costs.

³⁹ Alternative 1 (Continued mobile unit operation) is used as the reference.

6.0 Sensitivity Analysis

A sensitivity analysis was performed to determine which variables have the greatest influence on the results of the economic analysis and could potentially produce a different least-cost option. The following were the main variables or inputs that were assessed:

- Capital costs;
- Operating costs (overhauls and O&M);
- Fuel prices;
- Plant fuel efficiency;
- Load forecast;
- Discount rate;
- Salvage value of retired assets; and
- Renewable energy penetration.

The CPW breakouts in Figure 9 show that for each alternative, the largest contributors to the CPW total are fuel and project capital costs; therefore, it is expected that the economic analysis is most sensitive to changes in these factors. However, it is anticipated that there is a higher potential for greater fluctuations in capital costs. As illustrated in Figure 9, there is a marginal variation in the relative weight of these factors in each alternative.

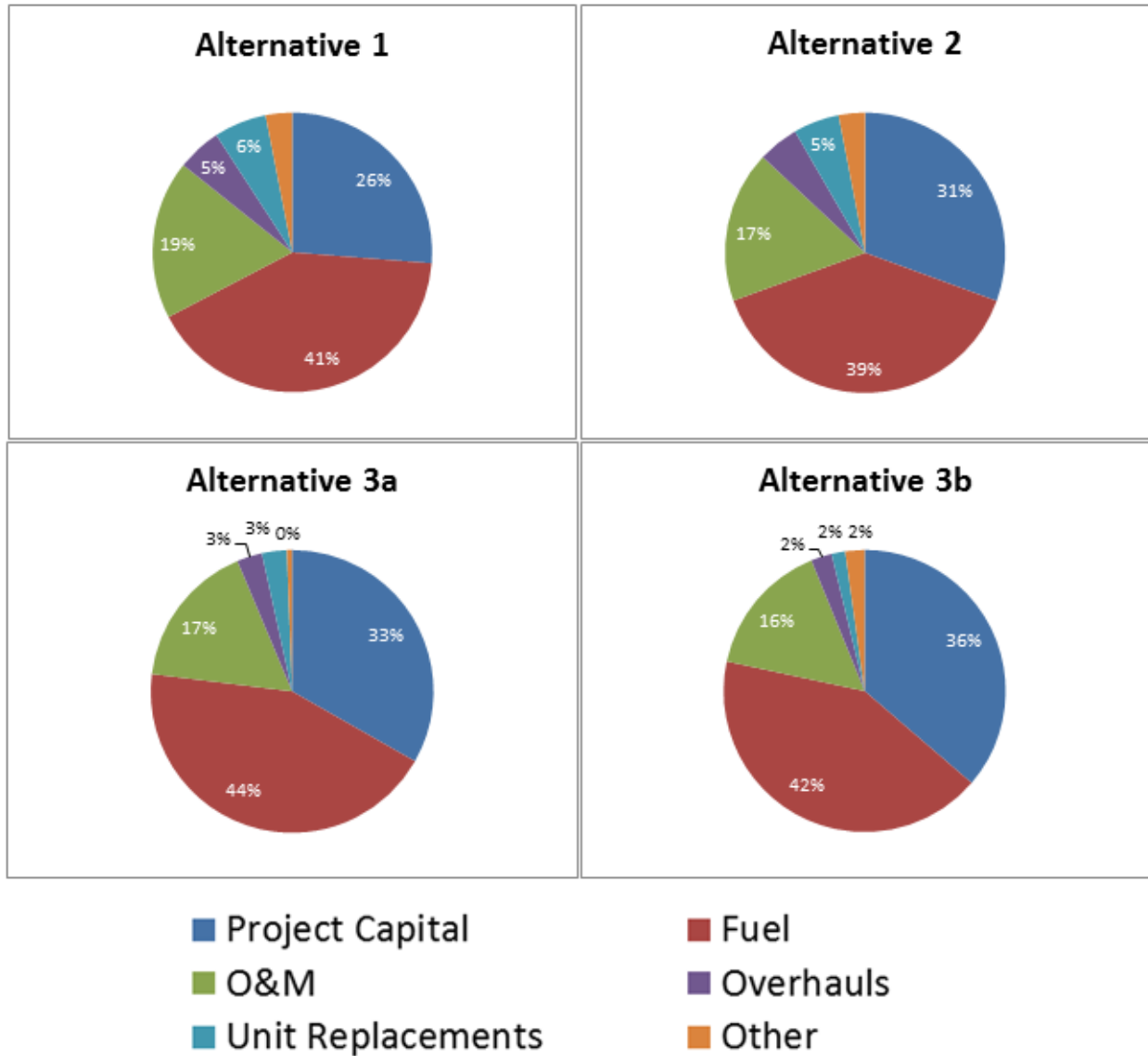

Figure 9: CPW Breakouts for Alternatives

1 **6.1 Project Capital Costs**

2 The project capital costs consist of expenditures associated with upfront capital, future project phases
 3 and future diesel generating station replacements. These capital costs contribute the most to the total
 4 CPW for each alternative (see Figure 9). For the purposes of this sensitivity analysis, capital costs were
 5 categorized as being associated with either line construction or diesel generating station construction.
 6 The analysis included an assessment of variations to the total capital costs, as well as to individual
 7 variations to each of the two cost categories. The relative weighting of these categories as a percentage
 8 of total capital cost for each alternative are shown in Table 14.

Table 14: Percent Breakout – Line Construction and Diesel Generating Station Construction Costs for Alternatives

Project	Line Construction Cost (% of Total Capital Cost)	Diesel Generating Station Construction Cost (% of Total Capital Cost)
Alternative 3a - Phase 1	36	64
Alternative 3a - Phase 2	81	19
Alternative 3a - Phase 3	97	3
Alternative 3b - Full Interconnection	54	46

1 The results of the analysis are summarized in Table 15 and involved varying the capital costs for each
 2 alternative until there was a change in the least-cost alternative. For example, considering case 5, if
 3 upfront diesel generating station costs for all alternatives decrease by 52.5% than the least-cost
 4 alternative becomes Alternative 3b instead of Alternative 3a. The capital costs were adjusted between -
 5 100% to +100%, where -100% equates to the project not being executed.

Table 15: Sensitivity Analysis – Impacts of Capital Cost Variations

Case	Cost Element Modified in Sensitivity Analysis	Percent Change	Least-Cost Option after Change	Probability of Occurrence
Upfront Capital Costs (2023 and 2024)				
1	Alternative 1 - New Mobile Building		No Change	
2	Alternative 2 - New CHT Diesel Generating Station		No Change	
3	Alternative 3a - Phase 1	+7.5%	Alternative 3b	High
4	Interconnection Costs (Upfront Only)	-12.5%	Alternative 3b	High
5	Diesel Generating Station Costs (Upfront Only)	-52.5%	Alternative 3b	50%
6	All Upfront Capital	-10.0%	Alternative 3b	High
7		+100.0%	Alternative 1	50%
8	Future Capital Costs (Beyond 2024)			
	Alternative 3a - Phase 2	+20.0%	Alternative 3b	High
9	Alternative 3a - Phase 3	+62.5%	Alternative 3b	50%
10	Diesel Generating Station Replacement Costs (Future Only)	-80.0%	Alternative 1	Low
11	All Capital Costs (2023-2070)			
	All Interconnection Costs	-35.0%	Alternative 3a	50%
12	All Diesel Generating Station Costs	-10.0%	Alternative 3b	High
13	All Capital Costs ⁴⁰	-25.0%	Alternative 3b	High

⁴⁰ This includes future project phases and diesel generating station/unit replacements.

1 The classification of the probability of occurrence for capital costs is based on the expected accuracy of a
2 Class 5 estimate which ranges between -20% to -50% and +30% to +100% with a 50% level of
3 confidence;⁴¹ therefore, any case where the percent change is within one of these ranges it is assumed
4 to have a 50% probability of occurrence. It is considered a 'High' probability of occurring when the
5 percentage change is between -20% and +30%, and 'Low' when it is less than -50% or greater than
6 +100%. The following are some of the key highlights that can be taken from Table 15:

- 7 • In all high probability sensitivity cases, alternatives involving interconnected solutions were
8 found to have the lowest CPW. There are seven scenarios where the probability of occurrence is
9 high which, if realized, would switch the least-cost option from Alternative 3a and Alternative
10 3b; however, a phased approach to interconnection is favoured for the following reasons:
 - 11 ○ Significant capital expenditures associated with future interconnection phases would be
12 deferred;
 - 13 ○ Such an approach would have less constructability risk and capital cost risk than an
14 immediate full interconnection; and
 - 15 ○ Through the execution of the first phase, cost estimates of future phases would have
16 improved accuracy. This would allow for further analysis to be performed upon project
17 completion and would provide a basis for the optimization of long term plans.
- 18 • The timing of the capital expenditure plays a significant factor in the sensitivity of a change to
19 capital cost.

20 Case 10 represents a scenario where the continued operation of mobile units at the Charlottetown
21 Diesel Generating Station would be preferred if all diesel generating station replacement costs could be
22 reduced by 80%. Reliable operation with such a significant reduction in expected capital expenditures is
23 deemed to be unsustainable. Further analysis indicates that even if diesel generating station
24 replacements are deferred by more than 20 years, the interconnected alternatives remain the most
25 economic solution.

26 On the basis of the above, interconnected solutions are likely to provide least-cost alternatives following
27 variations in capital costs. There is a moderate risk that continued mobile operation at Charlottetown

⁴¹ As per AASC Classifications.

1 would be the least-cost option in the event that upfront capital costs for all alternatives (Case 7) exceed
 2 estimates by more than 100%.

3 To address this risk, and given that results indicate a high likelihood that interconnected alternatives
 4 would have the lowest CPW, estimates for the first phases of the interconnections of Port Hope Simpson
 5 and Charlottetown for Alternative 3a and Alternative 1 were refined to a Class 4 level of accuracy. With
 6 this increased level of engineering, the accuracy is expected to be in the ranges of -15% to -30% and
 7 +20% to +50% with a 50% level of confidence. After applying the Class 4 estimates, sensitivity analysis
 8 indicates that continued operation of mobile generators at Charlottetown would only be the lowest-cost
 9 alternative if capital cost were to exceed estimates by 95%. Given the level of engineering and the
 10 expected accuracy of the Class 4 estimates for interconnected solutions, the probability of this outcome
 11 is low.

12 The results of the CPW analysis also indicate that there is not an appreciable difference between the
 13 interconnected alternatives in the context of the level of accuracy of the estimates. This is further
 14 supported by the sensitivity analysis, which indicates that highly probable shifts in capital costs would
 15 impact which alternatives would have the lowest CPW between the interconnected solutions.

16 6.2 Operations and Maintenance and Overhaul Costs

17 The results summarized in Table 16 suggest that a change in operating costs influences the outcome of
 18 the CPW analysis. An increase in O&M cost estimates by approximately 40% will result in Alternative 3b
 19 having the lowest CPW over 50 years.

Table 16: Sensitivity Analysis – O&M and Overhaul Costs

Operating Cost	Percent Change	Least-Cost Option after Change	Probability of Occurrence
Diesel O&M - All	+42.5%	Alternative 3b	Low
Diesel O&M – Excluding Regional Diesel Generating Station	+42.5%	Alternative 3b	Low
Diesel O&M – Regional Diesel Generating Station Only		No Change	
Interconnection O&M		No Change	
Overhaul		No Change	
Total O&M (Excluding Overhauls)	+55.0%	Alternative 3b	Low
Total O&M (Including Overhauls)	+45.0%	Alternative 3b	Low

6.3 Fuel Price and Plant Efficiency

The results summarized in Table 17 suggest that fuel prices have no significant influence on the outcome of the CPW analysis. Given that all supply options considered were thermal fuel-based solutions using the same fuel type, there was no change in the least-cost option when the low and high price forecast (see Appendix F) were applied and therefore the economic analysis is unaffected by fluctuations in fuel prices as defined in the fuel price forecasts. A change in plant efficiency could alter the results of the CPW analysis as shown in Table 17. However, the probability of occurrence is low for such changes in efficiency.

Table 17: Sensitivity Analysis – Fuel Price and Plant Efficiency

Factor	Percent Change	Least-Cost Option after Change	Probability of Occurrence
Diesel Generating Station Fuel Efficiency	-67.5%	Alternative 3b	Low
Fuel Efficiency - Existing Diesel Generating Stations	-17.5%	Alternative 3b	Low
Fuel Efficiency - New Diesel Generating Stations	25.0%	Alternative 3b	Low
	-50%	Alternative 1	Low
Fuel Price	Low Forecast High Forecast	No Change	

6.4 Load Growth

An increase in forecasted electricity consumption in southern Labrador is another sensitivity analysis consideration. The following are some of the factors that could increase electricity consumption within the region:

- The connection of a large commercial customer; and
- Changes in energy policy or technology which are conducive to the increased uptake of electric consumption by customers.

The forecast coincident peak for the entire southern Labrador system is about 3.6 MW by the year 2025. The southern Labrador interconnection would be designed to support approximately 8 MW of demand, assuming the incremental load is spread uniformly amongst the four communities. The capacity of each existing system is provided in Table 18, which is compared against the proposed capacity of a southern Labrador interconnection. It is evident from Table 18 that an interconnected solution provides a more effective capacity solution. Therefore, it can be concluded that some form of southern Labrador interconnection would be better equipped to accommodate incremental increases in demand.

1 A significant increase in the energy forecast had no impact on the CPW analysis. As demonstrated in
 2 Table 18, an interconnected solution inherently provides a greater capacity for each individual system.
 3 Therefore an incremental increase in demand driving a capacity upgrade would be expected to occur
 4 further into the future for an interconnected option compared to the status quo scenario, which would
 5 only increase the CPW difference between these options with no change to the lowest cost solution.

Table 18: Capacity of Southern Labrador Systems

System	Suggested Status Quo Capacity (kW) ⁴²	Assumed Limiting Component	Capacity following an Interconnection (kW) ⁴³	Capacity Increase (kW)
CHT	1,635	Generation	5,445	3,810
MSH	1,180	Distribution System	3,950	2,770
PHS	900	Substation	4,100	3,200
SLE	900	Substation	6,700	5,800

6.5 Other Economic Factors

7 The following were other economic factors that were assessed as part of the sensitivity analysis:

- 8 • Discount Rate: The discount rate would have to increase in excess of 13.1% for Alternative 1 to
 9 become the least-cost option, which would be unlikely to occur in the near term, at the time
 10 when the majority of the capital expenditures are applied.
- 11 • Salvage Value of Retired Assets: Any new asset replaced during the study period was assumed to
 12 have no salvaged at the end of the study (2070). A salvage value of 50% of remaining net book
 13 value of assets (2070) would result in Alternative 3a still being the lowest cost option.
- 14 • Carbon Tax: It was concluded that applying a carbon tax would have very little to no effect on
 15 the economic analysis.
- 16 • Renewable Energy Penetration: Assuming the purchase of renewable energy at 90% of fuel cost,
 17 it was concluded that consideration for renewable penetration (as per Appendix B) would have
 18 very little to no impact on the economic analysis.

⁴² The exact capacity of each system depends on where the load growth occurs. For this analysis it is assumed that load growth occurred near the end of the distribution system.

⁴³ This is the capacity of the distribution system without future upgrades, assuming no limits on the generation and substation capacity. The diesel generating station will have provisions to install additional generation and increase substation capacity.

1 Therefore, it can be concluded that the discount rate, salvage value of retired assets, carbon tax and
2 renewable energy penetration have a minimal impact on the results of the CPW analysis.

3 **6.6 Summary**

4 In the baseline economic analysis and in all sensitivity cases with a high level of probability,
5 interconnected solutions were found to have the lowest CPW. On this basis, an interconnected solution
6 is the recommended approach for supply to southern Labrador. As indicated in Section 6.1, a phased
7 approach was determined to be the lowest cost solution (Alternative 3a). A phased approach also has
8 the following benefits:

- 9 • Significant capital expenditures associated with future interconnection phases would be
10 deferred;
- 11 • Such an approach would have less constructability risk and capital cost risk than an immediate
12 full interconnection; and
- 13 • Through the execution of the first phase, cost estimates of future phases would have improved
14 accuracy. This would allow for further analysis to be performed upon project completion and
15 would provide a basis for the optimization of long-term plans.

16 It is therefore recommended that the first phase of Alternative 3a be undertaken as described in Section
17 4.3.

18 **7.0 Conclusion and Recommendations**

19 Based on the contents of this report and the analysis presented, the following conclusions have been
20 established:

- 21 • The current system configuration of three mobile gensets in Charlottetown is not an acceptable
22 long-term solution. The extended operation of mobile gensets would require capital investment
23 to meet long-term safety and reliability requirements. This is presented in Section 3.2.
- 24 • There is a lack of industry experience for the operation of modular plants in harsh northern
25 climates that experience significant snowfall. Given this consideration and the similar upfront
26 capital costs compared to a traditional diesel generating station, modular plant installations are
27 not a viable alternative at this time. This is presented in Section 3.3.

- 1 • The most favorable hydraulic generation scenario in the southern Labrador region to meet the
2 future supply needs in the area involves two hydroelectric developments on the St. Lewis and
3 Gilbert Rivers. This alternative is technically viable, but is not feasible due to the high capital cost
4 and environmental constraints in comparison to the other potential alternatives. This is
5 presented in Section 3.1.

- 6 • An interconnection to the Labrador Interconnected System at Happy Valley-Goose Bay was also
7 technically evaluated. High-level cost estimates prepared by Hydro indicated that the total
8 capital cost of such an interconnection would be in excess of \$400 million and due to the
9 magnitude of this cost it was removed from consideration.

- 10 • An analysis was performed that demonstrated that a 25 kV interconnection would improve the
11 overall reliability of southern Labrador systems. Refer to Appendix C.

- 12 • An analysis was performed that confirmed a southern Labrador interconnection would provide
13 more potential for renewable energy penetration in the four communities (Charlottetown,
14 Mary's Harbour, Port Hope Simpson, and St. Lewis). Refer to Appendix B.

- 15 • The economic analysis of alternatives indicates that interconnected solutions have the lowest
16 CPW in base case scenarios and also when considering likely sensitivities.

- 17 • In consideration of the phased interconnection alternatives, the solution involving the
18 connection of Charlottetown and Port Hope Simpson as a first stage is preferred (Alternative
19 3a).

20 On the basis of the above, the following recommendations are made with respect to the long-term
21 supply for southern Labrador:

- 22 • Proceed with an interconnected approach for the supply of southern Labrador;
- 23 • Proceed with a phased approach to the interconnection, involving the connection of
24 Charlottetown and Port Hope Simpson as a first stage (Alternative 3a); and
- 25 • Upon project completion, use updated cost estimates to revise economic analyses to determine
26 the optimal timing for future phases.



Appendix A

Operating Load Forecast (2020–2070)

Table A-1: Baseline Demand and Energy Forecast (Net)

Year	Net Demand (kW) – Summer Peak					Net Energy (MWh)				
	CHT	MSH	PHS	SLE	Combined ¹	CHT	MSH	PHS	SLE	Combined
2020	1,501	1,212	625	329	3,556	4,982	4,854	3,261	1,474	14,571
2021	1,507	1,218	627	329	3,571	5,002	5,021	3,275	1,474	14,773
2022	1,513	1,221	629	329	3,582	5,022	5,033	3,283	1,474	14,813
2023	1,520	1,224	631	329	3,592	5,043	5,044	3,292	1,474	14,853
2024	1,526	1,227	632	329	3,602	5,063	5,055	3,300	1,474	14,893
2025	1,532	1,230	634	329	3,613	5,084	5,067	3,308	1,474	14,933
2026	1,535	1,233	635	329	3,620	5,091	5,079	3,318	1,474	14,963
2027	1,537	1,236	636	329	3,626	5,099	5,092	3,328	1,474	14,993
2028	1,539	1,239	637	329	3,632	5,106	5,105	3,338	1,474	15,024
2029	1,542	1,242	638	329	3,638	5,114	5,117	3,348	1,474	15,054
2030	1,542	1,244	639	329	3,642	5,122	5,128	3,358	1,474	15,082
2031	1,543	1,247	640	329	3,646	5,129	5,138	3,368	1,474	15,110
2032	1,545	1,249	641	329	3,652	5,137	5,148	3,378	1,474	15,138
2033	1,548	1,252	642	329	3,657	5,145	5,159	3,388	1,474	15,166
2034	1,550	1,254	643	329	3,663	5,153	5,169	3,399	1,474	15,194
2035	1,551	1,257	643	329	3,667	5,155	5,179	3,409	1,474	15,218
2036	1,552	1,257	644	329	3,669	5,158	5,182	3,419	1,474	15,233
2037	1,552	1,258	645	329	3,671	5,160	5,184	3,429	1,474	15,248
2038	1,553	1,259	646	329	3,674	5,163	5,187	3,440	1,474	15,264
2039	1,554	1,259	647	329	3,676	5,165	5,190	3,450	1,474	15,279
2040	1,555	1,260	647	329	3,677	5,168	5,192	3,450	1,474	15,285
2041	1,555	1,260	647	329	3,678	5,171	5,193	3,450	1,474	15,288
2042	1,555	1,261	647	329	3,679	5,171	5,195	3,450	1,474	15,290
2043	1,555	1,261	647	329	3,679	5,171	5,196	3,450	1,474	15,291
2044	1,555	1,261	647	329	3,679	5,171	5,197	3,450	1,474	15,292
2045	1,555	1,262	647	329	3,679	5,171	5,199	3,450	1,474	15,294
2046	1,555	1,262	647	329	3,680	5,171	5,200	3,450	1,474	15,295
2047	1,555	1,262	647	329	3,680	5,171	5,201	3,450	1,474	15,296
2048	1,555	1,263	647	329	3,680	5,171	5,203	3,450	1,474	15,298
2049	1,555	1,263	647	329	3,681	5,171	5,204	3,450	1,474	15,299
2050	1,555	1,263	647	329	3,681	5,171	5,205	3,450	1,474	15,300
2051	1,555	1,263	647	329	3,681	5,171	5,205	3,450	1,474	15,300
2052	1,555	1,263	647	329	3,681	5,171	5,205	3,450	1,474	15,300
2053	1,555	1,263	647	329	3,681	5,171	5,205	3,450	1,474	15,300
2054	1,555	1,263	647	329	3,681	5,171	5,205	3,450	1,474	15,300
2055	1,555	1,263	647	329	3,681	5,171	5,205	3,450	1,474	15,300
2056	1,555	1,263	647	329	3,681	5,171	5,205	3,450	1,474	15,300
2057	1,555	1,263	647	329	3,681	5,171	5,205	3,450	1,474	15,300
2058	1,555	1,263	647	329	3,681	5,171	5,205	3,450	1,474	15,300
2059	1,555	1,263	647	329	3,681	5,171	5,205	3,450	1,474	15,300
2060	1,555	1,263	647	329	3,681	5,171	5,205	3,450	1,474	15,300
2061	1,555	1,263	647	329	3,681	5,171	5,205	3,450	1,474	15,300
2062	1,555	1,263	647	329	3,681	5,171	5,205	3,450	1,474	15,300
2063	1,555	1,263	647	329	3,681	5,171	5,205	3,450	1,474	15,300
2064	1,555	1,263	647	329	3,681	5,171	5,205	3,450	1,474	15,300
2065	1,555	1,263	647	329	3,681	5,171	5,205	3,450	1,474	15,300
2066	1,555	1,263	647	329	3,681	5,171	5,205	3,450	1,474	15,300
2067	1,555	1,263	647	329	3,681	5,171	5,205	3,450	1,474	15,300
2068	1,555	1,263	647	329	3,681	5,171	5,205	3,450	1,474	15,300
2069	1,555	1,263	647	329	3,681	5,171	5,205	3,450	1,474	15,300
2070	1,555	1,263	647	329	3,681	5,171	5,205	3,450	1,474	15,300

¹ The combined demand reflects the expected coincident summer demand for all systems combined and is not equal to the sum of individual system peaks. Coincident factor assumed to be 97%.



Appendix B

Southern Labrador - Renewable Energy Study

RP-TN-013

Southern Labrador - Renewable Energy Potential Study

Introduction

The purpose of this study is to quantify the amount of renewable energy penetration that could be achieved by the execution of a southern Labrador Interconnection supplied by a single regional diesel plant in Port Hope Simpson. A maximum amount of renewable energy was calculated for this proposed system configuration and was compared against the status quo, dedicated diesel plants supplying their respective system.

Background/Assumptions

The amount of allowable renewable energy penetration for each system is assumed to be limited based on the following restrictions:

1. The diesel plant will remain online 24/7 with the exception of unplanned or planned outages. All renewable energy sources must be disconnected during a diesel plant outage, to avoid the system from being served exclusively through renewable energy.
2. All online diesel units must operate above 40%¹ of its capacity. The maximum renewable energy potential for each option depends on the minimum diesel generation limit for each plant, which would be 40% of the rated capacity of the smallest unit.

There are a number of additional factors that may limit the amount of allowable renewable energy that were not considered in this analysis, since the purpose of this study is not to assess the technical and economical feasibility of specific renewable energy projects.

1. Economics of higher penetration levels –As renewable energy penetration increases the

¹ Hydro's requires that its diesel engines are loaded to a minimum of 40% whenever possible to avoid operational issues. An exception is in place for Mary's Harbour that allows engines to operate as low as 30% due to an existing power purchase agreement.

amount of generation and battery energy storage increases exponentially. Therefore the amount of allowable renewable energy calculated may not be economical.

2. The amount and/or type of renewable energy source(s) could adversely effect system stability and therefore the magnitude of renewable energy penetration could be limited.

The available renewable energy system capacity was calculated by subtracting the minimum diesel generation limit from available system load data for each 15 minute interval throughout an entire year. Each of these points were then added together to determine the potential energy that could be provided through renewable generation to offset diesel fuel.

Existing Systems

The southern Labrador communities of Charlottetown, Port Hope Simpson, and St. Lewis currently have no renewable energy generation sources connected to their distribution systems, leaving their entire potential available for use. There is a small hydro plant connected to the Mary's Harbour system, with a project underway to construct a photovoltaic and battery energy storage system ("PV/BESS") facility. These two facilities are owned by an independent power producer ("IPP") and sell electricity to Newfoundland and Labrador Hydro ("Hydro") through a power purchase agreement ("PPA"). The PPA states that the existing IPP has priority in providing the existing allowable renewable energy limit. The IPP expects to be able to generate approximately half² the allowable renewable energy available, leaving the other half still available. The estimated amount of renewable energy potential and the corresponding diesel fuel that could be offset by renewable energy in southern Labrador are provided in Table 1. The calculated amounts are theoretical values and assume the diesel plant is ideally operated.

² The Mary's Harbour IPP has indicated the potential to reduce fuel consumption from 300,000 to 400,000 L which is equivalent to 1.0–1.3 GWh of energy.

Regional Diesel Plant

The results of the study are presented in Table 1 which demonstrates an increase in renewable energy penetration potential with a southern Labrador interconnection compared to the status quo.

Table 1: Renewable Energy Potential In Southern Labrador

	Forecasted Gross Energy Demand (kWh)	Renewable Energy Maximum Potential (kWh)	Plant Efficiency (kWh/L)	Diesel Fuel Offset (L)
CHT	5,410,000	4,077,413	3.42	1,191,069
MSH	4,703,000	3,100,750	3.32	935,224
PHS	3,422,000	1,731,083	3.48	498,038
SLE	1,617,000	814,489	3.50	232,711
Isolated Southern Labrador Total	15,152,000	9,723,736	See Individual Plants	2,857,042
Interconnected Southern Labrador	15,152,000	11,186,734	3.70 ³	3,023,442
Difference (Interconnected – Isolated)	-	1,462,998	-	166,400

A southern Labrador interconnection supplied by a single diesel plant would serve a larger more diversified and stable load throughout the year.⁴ This change in demand characteristics would provide a greater opportunity to offset diesel consumption with renewable energy, reducing it by an estimated 170,000 L per year (See Table 1). The increase in renewable potential is attributed to the higher average demand, which increases the need for larger diesel units, and centralization which allows fewer units to serve the same load which decreases the minimum diesel generation limit. A southern Labrador interconnection would also reduce design restrictions to individual renewable energy facilities, allowing them to further optimize their renewable energy potential.

³ A regional plant efficiency of 3.70 kWh/L was assumed as it is the best efficiency hydro has recorded over the past five years. A new regional plant that has bigger engine sizes serving a load that is larger, more diversified and stable is expected to outperform any of Hydro's existing diesel plants.

⁴ This is based on less variance in monthly peak load as peaking season differ between communities, and that individual customers will have less of an impact on total system behavior as there is a larger system customer base.

The theoretical maximum allowable renewable energy that can currently be produced by an individual facility is 4 GWh located in Charlottetown. The southern Labrador interconnection could support up to 11.1 GWh anywhere in the southern Labrador region.

As well as offsetting more diesel fuel consumption with more renewable energy potential, a regional diesel plant could prove beneficial for renewable energy projects in a number of other ways. A single regional diesel plant serving all four communities would reduce the number of control systems that must be maintained and operated, which would decrease the cost associated with the integration of multiple renewable energy systems. A single control system at a regional diesel plant could command all renewable energy systems which would be a much simpler and cost effective strategy. A drawback to this approach is that a plant outage would force the disconnection of all renewable energy sources in southern Labrador. The regional plant could potentially require longer communication lines between the plant and renewable systems installed throughout southern Labrador.

Conclusion

A southern Labrador interconnection of Charlottetown, Mary's Harbour, Port Hope Simpson, and St. Lewis would allow for more renewable energy penetration in southern Labrador which has the potential to offset more fuel consumption in the future. The study shows that a single diesel generation source supplying a larger electrical load made up of four communities, would be a much more favourable and cost effective configuration for maximizing renewable energy potential in the region.

Document #: RP-TN-013

Document Summary

Document Summary

Document Owner:	Rural Planning
Document Distribution:	

Revision History

Revision	Prepared by	Reason for change	Effective Date
0	Tyler Stevens	Document creation	2020/08/21

Document Control

Regarding Transmission and Rural Planning documents: The electronic version of this document is the CONTROLLED version. Please check the Transmission and Rural Planning Document Management System SharePoint site for the official copy of this document. This document, when downloaded or printed, becomes UNCONTROLLED.

Appendix C

Southern Labrador Interconnection - Reliability Assessment

RP-TN-012

Southern Labrador Interconnection Reliability Assessment

Overview

The following study includes a reliability assessment to determine the impact that the proposed southern Labrador interconnection would have on the Mary's Harbour, Charlottetown, Port Hope Simpson, and St. Lewis power systems. This analysis presents the unavailability and expected unserved energy not supplied for both the existing and proposed systems and provides recommendations on the level of redundancy necessary to maintain existing reliability.

Background

The unavailability of a power system is calculated by combining the unavailability of each individual component of the power system. Currently, in the study area, this includes the existing diesel plant and distribution system. Following the proposed southern Labrador interconnection the entire system will include the regional diesel plant, the sub-transmission system, and the existing distribution systems.

Newfoundland and Labrador Hydro ("Hydro") tracks system reliability using the industry standard service continuity indexes; System Average Interruption Frequency Index ("SAIFI"),¹ and System Average Interruption Duration Index ("SAIDI").² To calculate the reliability impact of installing new assets and replacing equipment, the SAIFI and SAIDI values must be converted into a corresponding unavailability percentage. The unavailability percentage of a given system is calculated using historical SAIFI and SAIDI values through the following formula:

¹ SAIFI indicates the average number of power outages a customer has experienced in the respective distribution system per year.

² SAIDI indicates the average length of time a customer is without power in the respective distribution system per year.

$$\text{Unavailability Percentage} = \frac{\text{SAIFI} \times \text{SAIDI}}{8760} \times 100\%$$

The Expected Unserved Energy (“EUE”) is calculated by multiplying the systems unavailability with the system’s annual energy consumption.

Existing System

Table 1 provides the 2015 to 2019 average unavailability percentage data for the existing southern Labrador systems. This includes loss of supply (diesel plant) outages and distribution related outages. The regional indices are also presented for comparison purposes.

Table 1: Five Year Average Outage Statistics (2015 to 2019)

System	2015 - 2019 Average Unavailability (%) ³			EUE (MWh) ⁴
	All Causes	Loss of Supply	Distribution Related	
Southern Labrador Individual Systems (Average)	0.323%	0.177%	0.146%	48.90
Northern Region Isolated	0.435%	0.168%	0.267%	186.30
Labrador Region isolated	1.064%	0.254%	0.810%	342.48
Total Labrador Isolated	0.704%	0.205%	0.500%	528.79

Proposed System

To calculate the unavailability and EUE of the proposed southern Labrador interconnected system, an unavailability factor must be determined for the proposed regional diesel plant and the sub transmission system.⁵ It is assumed that the distribution related unavailability percentage would remain unchanged following the interconnection.

³ Weighted average.

⁴ EUE is calculated by multiplying the all causes unavailability by the 2019 forecasted Gross Energy Consumption for 2020 which was 5,410 MWh (CHT), 4,703 MWh (MSH), 3,422 MWh (PHS), 1,617 MWh (SLE), 15,152 MWh (South Labrador), 42,864 MWh (Northern), 32,197 MWh (Labrador Region), 75,061 MWh (Total Labrador).

⁵ Distribution Regulators were assumed to have no impact on reliability. When these devices malfunction it typically only affects their ability to regulate voltage and does not cause a system outage.

The unavailability of the regional diesel plant depends on the level of redundancy within the plant. If the regional diesel plant is configured to meet an N-1 firm capacity criteria, then it is assumed that the plant will have the same unavailability as the average of the four existing diesel plants.⁶ If the regional diesel plant is designed to meet an N-2 firm capacity criteria, then it is assumed that the unavailability will be equivalent to the average of St. Lewis and Port Hope Simpson.⁷

The unavailability of the proposed sub-transmission line is assumed to be approximately 0.213% per 100 km on the basis of benchmark statistics in consideration of Hydro's 66 kV transmission lines as well as 138 kV transmission line L1301. The proposed interconnection line will be built to a 66 kV transmission line standard and L1301 was considered to reflect the operation of the most comparable transmission line in Labrador. CEA reliability statistics as well as data for L1301 and Hydro's 66 kV transmission lines are provided in Table 2.

Table 2: Transmission Line Benchmark Statistics for Line Related Sustained Forced Outages

Voltage	Frequency (per 100 km/yr)	Mean Duration (h)	Unavailability (% per 100 km/yr)
CEA Average Up to 109 kV	2.8621	24.30	0.794%
Hydro 66 kV Statistics	1.4400	10.91	0.179%
L1301 - Churchill to Happy Valley	1.8266	10.23	0.213%

The CEA unavailability average contains lines of various environmental conditions, age, and fitness and is much higher than L1301 and Hydro's typical 66 kV transmissions line. Given the broad sample used in this statistic, Hydro considers this statistic less reflective of what to expect for the proposed 25 kV interconnection lines in southern Labrador. Hydro's 66 kV lines have similar outage statistics when compared to L1301 and between the two, L1301 is more conservative. On this basis an assumed unavailability of 0.179% was selected for the purposes

⁶ With an N-1 redundancy the regional diesel plant will have enough generation capacity to support the full system load in the event that the largest genset is unavailable. The unavailability for a diesel plant with this level of redundancy is assumed to be the average of the all existing diesel plants in the region as they are road connected communities designed with the level of redundancy as the regional plant.

⁷ With an N-2 redundancy the regional diesel plant will have enough generation capacity to support the full system load in the event that the two largest gensets are unavailable. The unavailability for a diesel plant with this level of redundancy is assumed to be the average of the existing diesel plants in St. Lewis and Port Hope Simpson as these plants can run with two units out of service for the majority of the year which aligns with the design of the proposed regional plant.

of this analysis.

Results

The calculated unavailability and EUE for the proposed southern Labrador interconnected systems including loss of supply (diesel plant) outages, sub-transmission system outages, and distribution related outages are presented Table 3. This table contains the calculated unavailability for each phase of interconnection as outlined in “Long-Term Supply Study for Southern Labrador: Economic & Technical Assessment.”

Table 3: Calculated Outage Statistics for Different Project Phases

System	Calculated Unavailability (%)				EUE (MWh) ⁹	Comparison to Existing Unserved Energy
	All Causes	Loss of Supply (Diesel Plant)	Sub Transmission System ⁸	Distribution Related		
Regional Plant with Charlottetown Connection						
CHT (N-1)	0.300%	0.139%	0.1027%	0.058%	16.22	Improved
CHT (N-2)	0.198%	0.037%	0.1027%	0.058%	9.31	Improved
Regional Plant with Charlottetown and Port Hope Simpson Connection						
CHT+PHS (N-1)	0.338%	0.139%	0.0629%	0.136%	29.82	Worsened
CHT+PHS (N-2)	0.236%	0.037%	0.0629%	0.136%	20.83	Improved
Regional Plant with Charlottetown, Port Hope Simpson, Mary's Harbour Connection						
CHT+MSH+PHS (N-1)	0.379%	0.139%	0.0781%	0.1619%	51.32	Worsened
CHT+MSH+PHS (N-2)	0.277%	0.037%	0.0781%	0.1619%	37.54	Improved
Full Southern Labrador Interconnection						
S. Lab. Regional Plant (N-1)	0.367%	0.139%	0.0816%	0.146%	55.61	Worsened
S. Lab. Regional Plant (N-2)	0.265%	0.037%	0.0816%	0.146%	40.18	Improved

The reduction in unavailability and EUE shown in Table 3 indicates that the Southern Labrador

⁸ The interconnection line lengths to each community were assumed for calculation purposes to be as follows: 48.1 km to CHT, 50 km to MSH, 0 km to PHS, and 52.1 km to SLE.

⁹ EUE calculated by multiplying the all causes unavailability by the 2019 forecasted Gross Energy Consumption for 2020 which was 5,410 MWh (CHT), 4,703 MWh (MSH), 3,422 MWh (PHS), 1,617 MWh (SLE), 15,152 MWh (South Labrador).

Interconnection would improve reliability as long as the regional diesel plant has a redundancy of N-2. Once the full southern Labrador region is interconnected the calculated unavailability (0.265%) is less than the average unavailability of the four existing southern Labrador systems (0.323%) and the Labrador regional average unavailability (0.704%) as indicated in Table 4.

Table 4: Calculated Outage Statistics for Proposed Southern Labrador Interconnection

System	Calculated Unavailability (%)				EUE (MWh)
	All Causes	Loss of Supply (Diesel Plant)	Sub Transmission System	Distribution Related	
Southern Labrador Systems	0.323%	0.177%	-	0.146%	48.90
Labrador Region	0.704%	0.205%	-	0.500%	528.79
Southern Labrador. Regional Plant (N-1)	0.367%	0.139%	0.0816%	0.146%	55.61
Southern Labrador Regional Plant (N-2)	0.265%	0.037%	0.0816%	0.146%	40.18

Additional Notes

In addition to reliability and EUE improvements indicated in the above analysis, some aspects of the southern Labrador interconnection project are expected to improve reliability or performance in the communities, but are not able to be incorporated into the unavailability calculations. The identified and unquantified benefits of this project include:

1. The regional diesel plant would have a fully connected standby 3-phase step-up padmount transformer at the diesel plant in the event that one fails. Currently the individual diesel plants have single-phase pole top transformers with a spare available for replacement.
2. The new interconnection lines and 25 kV voltage conversion would require some pole and conductor replacements, as well as the replacement of all step-down transformers, which could reduce distribution related outages.
3. The new interconnection lines would be built alongside the highway which could result in improved reliability as the lines would be more accessible for maintenance and

troubleshooting. A large portion of L1301 and some of Hydro's 66 KV transmission lines do not have this operational luxury.

4. The proposed interconnection line would be a new construction and could initially have better reliability performance than the older L1301 line.
5. All other opportunities to improve reliability, specifically related to the diesel plant and loss of supply, would be considered as part of the detailed design phase of the project.

Conclusion

A southern Labrador interconnection would improve the overall system performance of the southern Labrador isolated diesel systems as long as the regional diesel plant has a redundancy of N-2. This would improve the overall unavailability average of the four communities by 0.058%, which is equal to approximately 8.72 MWh of EUE or a 5.08 hour reduction in time spent without power per year. This project will also provide many benefits that were not able to be quantified in the reliability calculations which will have operational and planning benefits and could further improve system reliability beyond what was calculated. Overall the proposed interconnection is expected to improve the overall reliability of the southern Labrador system.

Document #: RP-TN-012

Document Summary

Document Summary

Document Owner:	Rural Planning
Document Distribution:	

Revision History

Revision	Prepared by	Reason for change	Effective Date
1	Tyler Stevens	Document creation	2020/08/21

Document Control

Regarding Transmission and Rural Planning documents: The electronic version of this document is the CONTROLLED version. Please check the Transmission and Rural Planning Document Management System SharePoint site for the official copy of this document. This document, when downloaded or printed, becomes UNCONTROLLED.

Appendix D

Rural Planning Standard – Rural Isolated Systems Generation Planning Criteria

RURAL PLANNING STANDARD

Rural Isolated Systems Generation Planning Criteria

Doc # RP-S-002

Date: 2020/08/21

Table of Contents

1	PURPOSE	1
2	TERMS, ABBREVIATIONS, AND ACRONYMS.....	2
3	INTRODUCTION	3
4	RURAL PLANNING CRITERIA	4
4.1	Capacity.....	4
4.1.1	Firm Capacity Planning Criteria.....	4
4.2	Energy.....	5
4.2.1	Vender Delivered Fuel:.....	5
4.2.2	Bulk Fuel Storage.....	5
4.3	Diesel Plant Equipment.....	6
4.4	Diesel Plant Substations.....	6

1 PURPOSE

The purpose of this document is to present Rural Isolated Generation Planning Criteria to be applied to the diesel generation plants within the Province of Newfoundland and Labrador.

2 TERMS, ABBREVIATIONS, AND ACRONYMS

Firm Capacity: means the amount of capacity that can be reasonably guaranteed from a generating unit at a particular instant when required. In the case of capacity planning, it describes the capacity that can be expected from a diesel generating plant during the system peak load.

Standby Power:¹ Output available with varying load for the duration of the interruption of the normal source power. Average power output is 70% of the standby power rating. Typical operation is 200 hours per year, with maximum expected usage of 500 hours per year.

Prime Power:¹ Output available with varying load for an unlimited time that is typically 90% of Standby Power Rating. Average power output is 70% of the prime power rating. Typical peak demand is 100% of prime rated kW with 10% overload capability for emergency use for a maximum of 1 hour in 12. Overload operation cannot exceed 25 hours per year.

Continuous Power:¹ Output available with non-varying load for an unlimited time that is typically 70% of Standby Power Rating. Average power output is 70-100% of the continuous power rating. Typical peak demand is 100% of continuous rated kW for 100% of operating hours.

¹ Based on the IOS8528 Standard.

3 INTRODUCTION

A Rural Isolated System is an electric power system that is isolated from either the island or Labrador Grid, and is typically supplied by diesel based generation. Newfoundland and Labrador Hydro (“Hydro”) has established criteria related to the appropriate reliability, at the generation level, for the system that sets the timing of generation source additions. These criteria set the minimum level of reserve capacity and energy installed in the system to ensure an adequate supply for firm demand; however, short-term deficiencies can be tolerated if the deficiencies are of minimal incremental risk. As a general rule to guide Hydro's planning activities for Rural Isolated Systems the following have been adopted.

4 RURAL PLANNING CRITERIA

4.1 Capacity

Capacity for Rural Isolated Systems is provided by diesel generating plants which house a number of diesel generator sets (“gensets”). The minimum number of units in a diesel plant is three, and typical plant size is from three to four units, although some (typically larger) plants contain more units. The prime power rating of the gensets is used to calculate the firm capacity in the rural isolated diesel plants. Gensets are assumed to be capable of achieving their respective nameplate ratings throughout their lifecycle.

In some cases power is also supplied to the system by alternative energy sources such as wind, solar, and small hydro. To date, wind and solar are considered as non-firm energy sources even when coupled with an energy storage system. That is, the wind and/or solar generation are not considered to provide firm capacity to the system during peak load. This is due to the random nature of the energy supply (wind/solar) which will not necessarily be present when it is needed. In the case of hydro-electric plants, run-of-river plants, are treated the same as wind or solar, and provide no firm capacity to the system during peak load. A hydro-electric plant with a storage reservoir will provide some degree of firm capacity to the system. The amount of capacity is dependant on the particular site and the design of the plant.

Hydro applies firm capacity criteria, which considers all the firm power sources available to the system, when determining the amount of capacity needed to supply the system’s peak load according to the five year load forecast. The criterion used to guide Hydro’s planning activities in relation to system capacity is described below.

4.1.1 Firm Capacity Planning Criteria

Hydro’s generation reliability criterion for the Isolated Rural Systems is stated as follows: Hydro shall maintain firm generation capacity to meet the system peak load. Firm generation capacity is defined as the total installed capacity on the system not including non-firm energy sources as noted above minus the largest single unit. Exemptions or modifications to this criterion may be considered in the following situations:

- Additional generation may be prudent in situations where the introduction of a subtransmission system supplying multiple communities decreases existing system reliability.
- Less generation may be prudent in situations where non-firm generation has a historical record of operating at a low unavailability rate.
- Additional generation may be prudent in situations where major diesel plant modifications, such as the construction of a new diesel plant or major extension, are planned and the cost to add additional generation is of minor incremental cost.

Rationale:

The Firm Capacity Planning Criteria covers a first contingency situation. It is considered to provide a reasonable level of reliability to customers in the Rural Isolated Systems, and gives a good compromise between cost of service and reliability. Hydro has a long standing practice of using this criterion with good success. A survey conducted by Hydro in 2007 has confirmed that this criterion is similarly

practiced in other utilities. This criterion can be reasonably considered to be an industry standard practice.

4.2 Energy

Energy for Rural Isolated Systems is provided from either Type A (Arctic Grade), or Type B Diesel Fuel supplied by a local fuel vendor or stored on site by Hydro. Where cost effective, Hydro will contract with a local fuel vendor for supply of diesel fuel to the diesel plants. In cases where this arrangement is not feasible, or not possible, Hydro will maintain long-term bulk fuel storage at the site. The amount of fuel to store is planned such that the diesel plant can supply energy requirements of the system over the winter period when fuel deliveries to the site are unavailable.

4.2.1 Vender Delivered Fuel:

In the case where Hydro relies on a contract with a local fuel vendor, the following criteria are used to guide Hydro's planning criteria.

- Sufficient fuel shall be stored on site, such that the energy requirements of the system can be met for two weeks at all times of the year.
- The total available fuel storage capacity required on site shall meet the energy requirements of the system for a minimum of three weeks at all times of the year.

Assumptions:

- The local fuel vendor has enough storage to meet Hydro's winter fuel requirements.
- The local fuel vendor is scheduled to fill up Hydro's storage at least once every seven days.
- If more than 21 days of storage is available, then deliveries may occur less often.
- If a location has a much higher, or lower risk of delay in fuel storage than then typical, additional, or less fuel storage may be required.

Rationale:

For planning purposes a fuel delivery of once every seven days is assumed because fuel carrying ferries operate on a weekly schedule. The Fuel Storage Planning Criteria covers the contingency situation of a one week delay in fuel delivery. If the vendor fills Hydro's storage every 7 days and Hydro's fuel storage is large enough for at least 21 days of fuel then there should always be at least 2 weeks of fuel in storage. If the vendor cannot supply fuel on the 7th due to an emergency (pipe failure, pump failure, or ferry delay, etc.) there is 2 weeks fuel available for backup.

4.2.2 Bulk Fuel Storage

In the case where Hydro must maintain long-term bulk fuel storage, the following criteria are used to guide Hydro's planning activities.

- Island Isolated Systems; sufficient fuel shall be stored on site, such that the energy requirements of the system can be met for four consecutive months.
- Labrador Isolated Systems; sufficient fuel shall be stored on site, such that the energy requirements of the system can be met for nine consecutive months.

Assumptions:

- Final Fuel delivery via shuttle tanker is in late November.
- Hydro's fuel requirements are communicated to the vendor in the fall before the final fuel delivery.

Rationale:

The Fuel Storage Planning Criteria covers a first contingency situation. It is considered to provide a reasonable level of reliability to customers in physically isolated communities, and gives a good compromise between cost of service and reliability. Hydro has a long standing practice of using this criterion with good success. A survey conducted by Hydro in 2007 revealed that most other utilities surveyed only maintain short-term fuel storage and rely on deliveries from fuel vendors. Only one utility surveyed maintained long-term bulk fuel storage. It appears that fuel storage practices are region specific and dependant on the local resources available (i.e., road access, local fuel vendor, etc.).

4.3 Diesel Plant Equipment

In addition to generating capacity, and energy, Hydro plans the capacity of the major diesel plant equipment that is responsible for getting the power from the individual diesel units to the power distribution system. The components covered under this criterion are the main breaker, main bus, and service conductors and is defined as follows:

Diesel Plant Equipment Capacity Planning Criteria

No equipment shall be loaded above 100% of its rated capacity at rated ambient temperature.

Assumptions:

- The ratings are continuous ratings.
- Ambient temperature is thirty degrees Celsius.

4.4 Diesel Plant Substations

Capacity planning of diesel plant substations (step-up transformers) is covered under Hydro's Distribution Planning Criteria. The criteria are reiterated here since the substation forms the critical interface between the diesel plant and the distribution system.

Substation Capacity Planning Criteria

Transformers at substations shall not be loaded above 110% of the nameplate rating.

In the case of diesel plant substations; a spare shall be retained on site such that in the event of the loss of a single unit; the spare can be installed to restore power within a reasonable time frame. The standard substation is an aerial bank of three single-phase transformers connected in a three-phase bank. The maximum size aerial bank is 1500 kVA (3 x 500 kVA). This transformer size was selected since

it is considered to be the largest size transformer that can be handled without assistance from a bucket truck, or crane.

If transformer capacity exceeding the maximum size aerial bank is required a three-phase padmount transformers may be used. Due to the size of these units and the remote nature of these plants, the equipment and personnel required to replace a three-phase transformer may not be available when needed. To prevent a prolonged system outage, in the event of a three-phase transformer failure, a second padmount transformer may be installed and available as a spare to use when required.

Document Summary

Document Owner:	Rural Planning
Document Distribution:	Rural Planning

Revision History

Revision	Prepared by	Reason for change	Effective Date
1	Tyler Stevens	Updated and included in DMS	2020/08/21

Document Approvers

Position	Signature	Approval Date
Team lead, Rural Planning	<i>Scott Henderson</i>	Sept 17, 2020

Document Control

Regarding Transmission and Rural Planning documents: The electronic version of this document is the CONTROLLED version. Please check the Transmission and Rural Planning Document Management System SharePoint site for the official copy of this document. This document, when downloaded or printed, becomes UNCONTROLLED.

Appendix E

Single-Line Diagrams

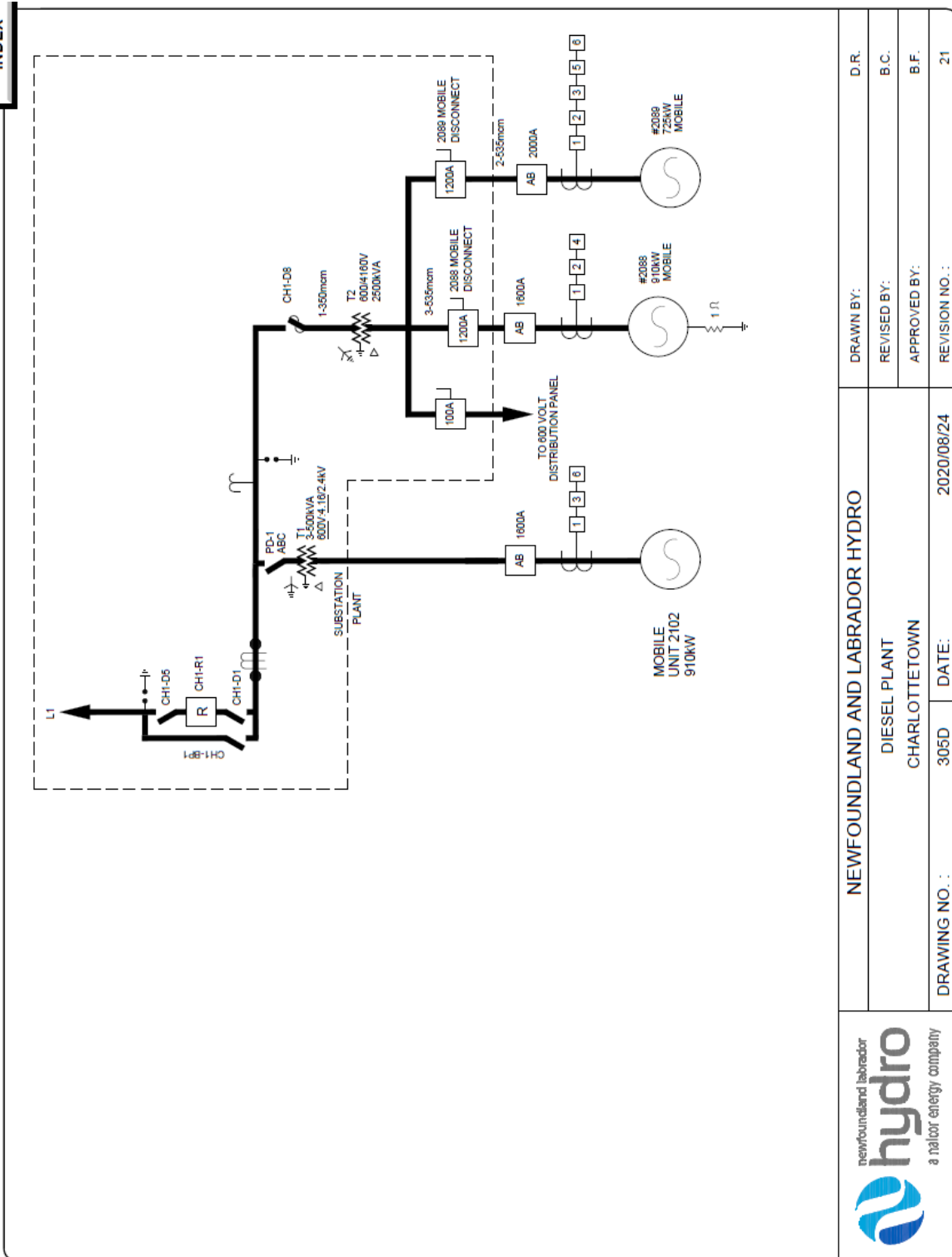

	NEWFOUNDLAND AND LABRADOR HYDRO		DRAWN BY:	D.R.
	DIESEL PLANT CHARLOTTETOWN		REVISED BY:	B.C.
DRAWING NO. : 305D		DATE: 2020/08/24	APPROVED BY:	B.F.
			REVISION NO. :	21

Notes:
Charlottetown:

- (1) Plant to be designed to accommodate 5 x 1,000 kVA units. Sizes could vary between 600 kW, 800 kW, and 1000 kW (will be finalized as part of detailed design phase)
- (2) 1200 rpm, 4160 volt diesel generators, and associated ancillary equipment including cooling and exhaust systems. Each diesel generator will be equipped with a dedicated radiator.
- (3) 4.16kV Unit Vacuum Circuit Breaker, 5kV Class, BIL TBD, 400A, interrupting rating TBD
- (4) 4.16kV Reclosers, 12kA Interrupting Rating (to be confirmed)
- (5) Station Service Transformer. 4.16:208Y/120 kV (600 A)
- (6) New three-phase 4.16kV distribution line to fish plant, 477 ACR conductor

Future Considerations:

- MSH Plant Replacement (Year 2025)
- PHS Plant Replacement (Year 2035)
- SLE Plant Replacement (Year 2045)

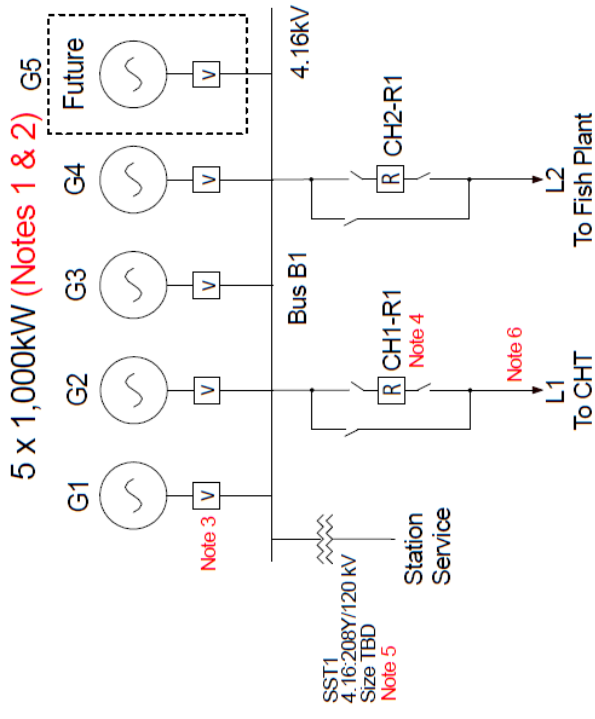

SYS PLAN:	SHEET 1 OF 1
SYS OP:	DATE: 2/26/2020
ELEC:	DRAWN BY: MFC
P&C:	REVISION: 1
FILE:	South Lab Inter - Alt 2.SKF

Alternative 2 - New Diesel Plant in CHT



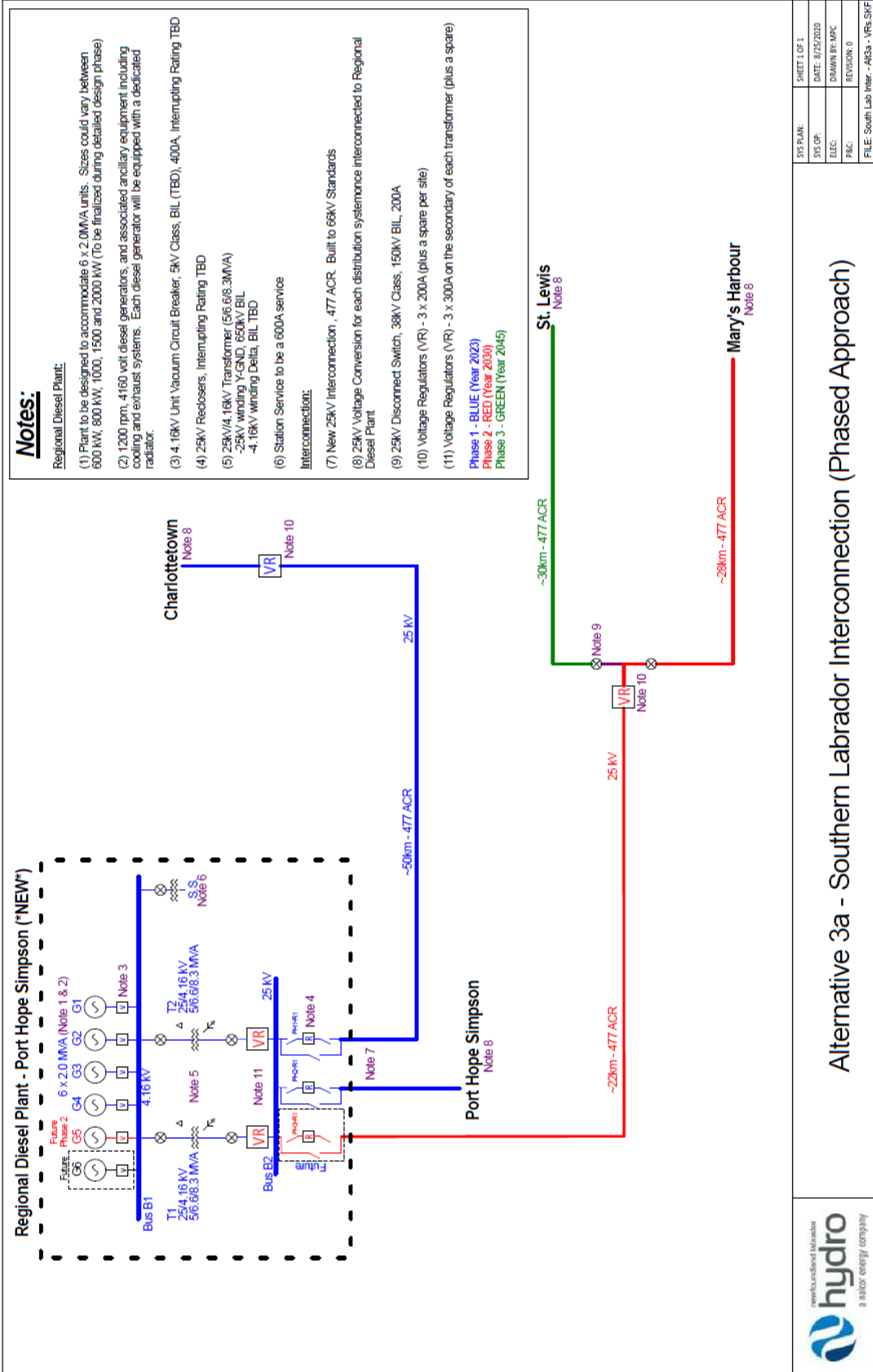

Notes:

- Regional Diesel Plant:
- (1) Plant to be designed to accommodate 6 x 2.0MVA units. Sizes could vary between 600 kW, 800 kW, 1000, 1500 and 2000 kW (To be finalized during detailed design phase)
 - (2) 1200 ppm, 4160 volt diesel generators, and associated ancillary equipment including cooling and exhaust systems. Each diesel generator will be equipped with a dedicated radiator.
 - (3) 4.16kV Unit Vacuum Circuit Breaker, 5kV Class, BIL (TBD), 400A, Interrupting Rating TBD
 - (4) 25kV Reducers, Interrupting Rating TBD
 - (5) 25kV/4.16kV Transformer (516.6/8.3MVA)
 - 25kV winding Y-GND, 650kV BIL
 - 4.16kV winding Delta, BIL TBD
 - (6) Station Service to be a 600A service
- Interconnection:
- (7) New 25kV Interconnection, 477 ACR, Built to 66kV Standards
 - (8) 25kV Voltage Conversion for each distribution system/interconnection to Regional Diesel Plant
 - (9) 25kV Disconnect Switch, 38kV Class, 150kV BIL, 200A
 - (10) Voltage Regulators (VR) - 3 x 200A (plus a spare per site)
 - (11) Voltage Regulators (VR) - 3 x 300A on the secondary of each transformer (plus a spare)
- Phase 1 - BLUE (Year 2022)
 Phase 2 - RED (Year 2020)
 Phase 3 - GREEN (Year 2045)

SYS PLAN:	SHEET 1 OF 1
SYS OP:	DATE: 8/25/2020
ELEC:	DRAWN BY: MPC
PKG:	REVISION: 0
FILE: South Lab Inter - A03a - VRs-SKF	

Alternative 3a - Southern Labrador Interconnection (Phased Approach)



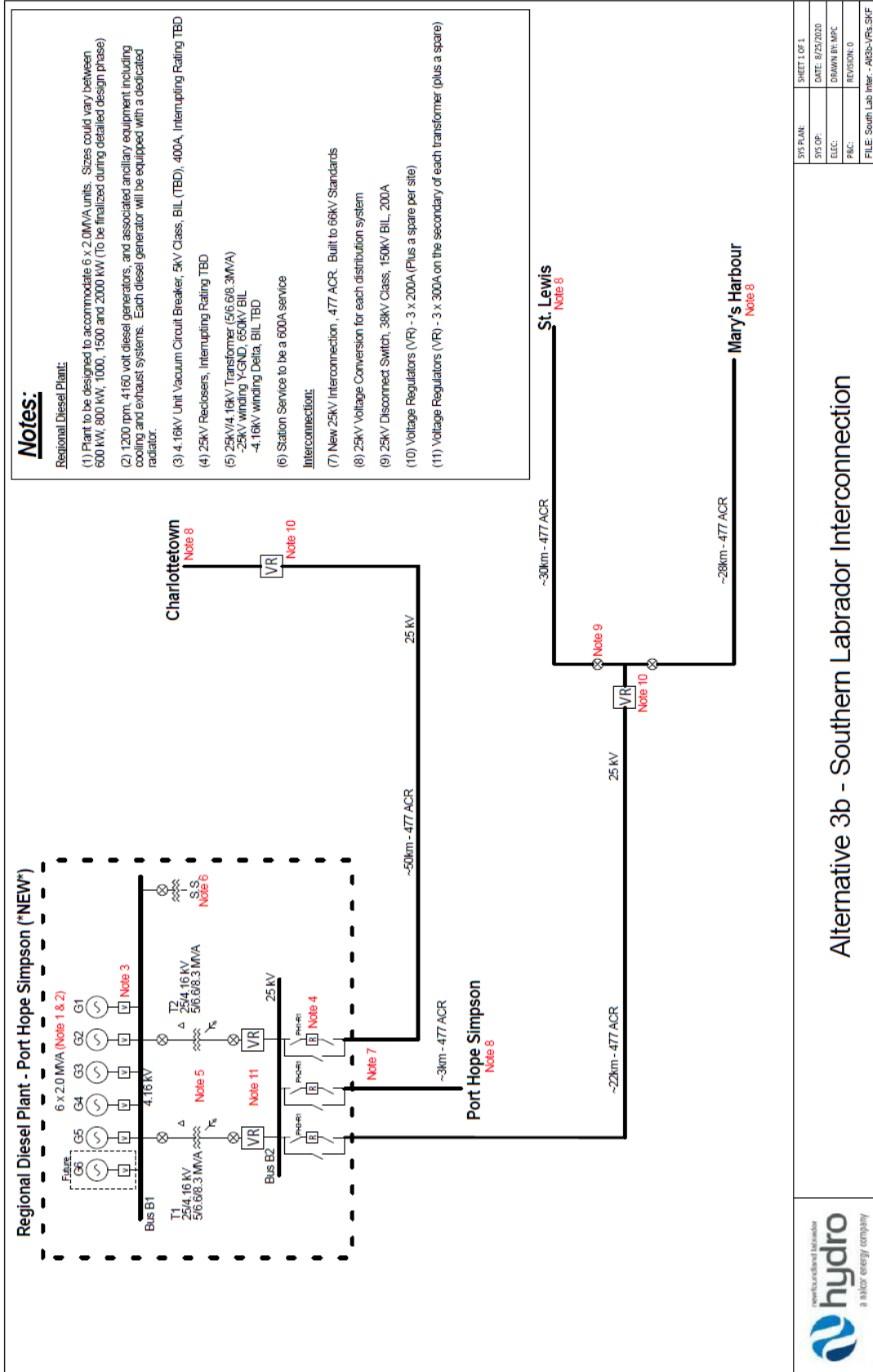

Notes:

- Regional Diesel Plant:**
- (1) Plant to be designed to accommodate 6 x 2.0MVA units. Sizes could vary between 600 kW, 800 kW, 1000, 1500 and 2000 kW (to be finalized during detailed design phase)
 - (2) 1200 rpm, 4160 volt diesel generators, and associated ancillary equipment including cooling and exhaust systems. Each diesel generator will be equipped with a dedicated radiator.
 - (3) 4.16kV Unit Vacuum Circuit Breaker, 5kV Class, BIL (TBD), 400A, Interrupting Rating TBD
 - (4) 25kV Reclosers, Interrupting Rating TBD
 - (5) 25kV/4.16kV Transformer (5/6.68.3MVA)
 - 25kV winding Y-GND, 650kV BIL
 - 4.16kV winding Delta, BIL TBD
 - (6) Station Service to be a 600A service
- Interconnection:**
- (7) New 25kV Interconnection, 477 ACR. Built to 66kV Standards
 - (8) 25kV Voltage Conversion for each distribution system
 - (9) 25kV Disconnect Switch, 38kV Class, 150kV BIL, 200A
 - (10) Voltage Regulators (VR) - 3 x 200A (Plus a spare per site)
 - (11) Voltage Regulators (VR) - 3 x 300A on the secondary of each transformer (plus a spare)

SYS PLAN:	SHEET 1 OF 1
SYS OP:	DATE: 8/25/2020
ELEC:	DESIGN BY: MFC
P&C:	REVISION: 0
FILE:	South Lab Inter - AK3b-VRs.SKF

Alternative 3b - Southern Labrador Interconnection





Appendix F

Diesel Fuel Price Forecasts (2020–2070)

Table F-1: Baseline Fuel Price Forecast (\$CDN/L)

Year	CHT	MSH	PHS	SLE
2020	0.696	0.676	0.820	0.806
2021	0.758	0.738	0.882	0.868
2022	0.845	0.845	0.885	0.870
2023	0.925	0.925	0.965	0.950
2024	0.960	0.960	1.000	0.990
2025	0.940	0.940	0.980	0.970
2026	0.960	0.960	1.000	0.990
2027	0.980	0.980	1.020	1.010
2028	1.000	1.000	1.040	1.025
2029	1.015	1.015	1.060	1.050
2030	1.035	1.035	1.085	1.070
2031	1.060	1.060	1.105	1.090
2032	1.075	1.075	1.125	1.110
2033	1.095	1.095	1.145	1.130
2034	1.115	1.115	1.165	1.150
2035	1.135	1.135	1.185	1.170
2036	1.155	1.155	1.205	1.190
2037	1.170	1.170	1.220	1.205
2038	1.185	1.185	1.240	1.225
2039	1.205	1.205	1.260	1.240
2040	1.220	1.220	1.275	1.26
2041	1.245	1.245	1.305	1.285
2042	1.270	1.270	1.330	1.310
2043	1.295	1.295	1.355	1.335
2044	1.325	1.325	1.385	1.365
2045	1.350	1.350	1.410	1.390
2046	1.375	1.375	1.440	1.420
2047	1.405	1.405	1.465	1.445
2048	1.430	1.430	1.495	1.475
2049	1.459	1.459	1.525	1.505
2050	1.488	1.488	1.555	1.535
2051	1.518	1.518	1.587	1.565
2052	1.548	1.548	1.618	1.597
2053	1.579	1.579	1.651	1.629
2054	1.610	1.610	1.684	1.661
2055	1.643	1.643	1.717	1.694
2056	1.675	1.675	1.752	1.728
2057	1.709	1.709	1.787	1.763
2058	1.743	1.743	1.822	1.798
2059	1.778	1.778	1.859	1.834
2060	1.814	1.814	1.896	1.871
2061	1.850	1.850	1.934	1.908
2062	1.887	1.887	1.973	1.946
2063	1.925	1.925	2.012	1.985
2064	1.963	1.963	2.052	2.025
2065	2.002	2.002	2.093	2.065
2066	2.042	2.042	2.135	2.107
2067	2.083	2.083	2.178	2.149
2068	2.125	2.125	2.221	2.192
2069	2.167	2.167	2.266	2.236
2070	2.211	2.211	2.311	2.280

1 **Assumptions (Table F-1)**

- 2 • Price forecast reflects the delivered cost of No. 2 fuel specifications used by Hydro.
- 3 • Pricing excludes carbon taxation as per Government of Newfoundland and Labrador Carbon
- 4 Plan.
- 5 • Price forecast reflects existing fuel supply delivery methods. Price margins between Port Hope
- 6 Simpson and Mary's Harbour reflect historical fuel supply contract price margins. Price margins
- 7 between Port Hope Simpson and St. Lewis reflect existing fuel supply contract price margins.
- 8 • Basis for 2020–2040 price forecast is Platts Analytics fuel price outlook, June 2020 WOMF and
- 9 May 2020 SPS Long Term. Post-2040 price forecast reflects price inflation of 2%.

Table F-2: Diesel Fuel Low Price Sensitivity Forecast (\$/CDN/L)

Year	CHT	MSH	PHS	SLE
2020	0.420	0.408	0.495	0.487
2021	0.414	0.403	0.482	0.475
2022	0.587	0.587	0.615	0.605
2023	0.663	0.663	0.691	0.680
2024	0.704	0.704	0.733	0.726
2025	0.744	0.744	0.775	0.767
2026	0.822	0.822	0.856	0.848
2027	0.834	0.834	0.868	0.859
2028	0.836	0.836	0.869	0.857
2029	0.831	0.831	0.868	0.860
2030	0.829	0.829	0.869	0.857
2031	0.831	0.831	0.867	0.855
2032	0.828	0.828	0.866	0.855
2033	0.832	0.832	0.870	0.859
2034	0.835	0.835	0.873	0.862
2035	0.843	0.843	0.881	0.869
2036	0.849	0.849	0.886	0.875
2037	0.854	0.854	0.890	0.879
2038	0.860	0.860	0.900	0.889
2039	0.872	0.872	0.911	0.897
2040	0.877	0.877	0.917	0.906
2041	0.895	0.895	0.939	0.924
2042	0.913	0.913	0.957	0.942
2043	0.931	0.931	0.975	0.960
2044	0.953	0.953	0.996	0.982
2045	0.971	0.971	1.014	1.000
2046	0.989	0.989	1.036	1.021
2047	1.011	1.011	1.054	1.039
2048	1.029	1.029	1.075	1.061
2049	1.049	1.049	1.097	1.082
2050	1.070	1.070	1.119	1.104
2051	1.091	1.091	1.141	1.126
2052	1.113	1.113	1.164	1.148
2053	1.136	1.136	1.187	1.171
2054	1.158	1.158	1.211	1.195
2055	1.181	1.181	1.235	1.219
2056	1.205	1.205	1.260	1.243
2057	1.229	1.229	1.285	1.268
2058	1.254	1.254	1.311	1.293
2059	1.279	1.279	1.337	1.319
2060	1.304	1.304	1.364	1.345
2061	1.330	1.330	1.391	1.372
2062	1.357	1.357	1.419	1.400
2063	1.384	1.384	1.447	1.428
2064	1.412	1.412	1.476	1.456
2065	1.440	1.440	1.506	1.485
2066	1.469	1.469	1.536	1.515
2067	1.498	1.498	1.566	1.545
2068	1.528	1.528	1.598	1.576
2069	1.559	1.559	1.630	1.608
2070	1.590	1.590	1.662	1.640

1 **Assumption (Table F-2)**

- 2 • Price forecast reflects the delivered cost of No. 2 fuel specifications used by Hydro.
- 3 • Pricing excludes carbon taxation as per Government of Newfoundland and Labrador Carbon
4 Plan.
- 5 • Price forecast reflects existing fuel supply delivery methods. Price margins between Port Hope
6 Simpson and Mary's Harbour reflect historical fuel supply contract price margins. Price margins
7 between Port Hope Simpson and St. Lewis reflect existing fuel supply contract price margins.
- 8 • Basis for 2020–2040 price forecast is Platts Analytics low crude price outlook, May 2020 SPS
9 Long Term. Post-2040 price forecast reflects price inflation of 2%
- 10 • Low price projection does not consider possible US-CDN FX effects on fuel pricing that would
11 inflate prices

Table F-3: Diesel Fuel High Price Sensitivity Forecast (\$CDN/L)

Year	CHT	MSH	PHS	SLE
2020	0.827	0.804	0.974	0.958
2021	0.981	0.955	1.141	1.124
2022	1.358	1.358	1.422	1.398
2023	1.444	1.444	1.506	1.483
2024	1.494	1.494	1.556	1.541
2025	1.545	1.545	1.611	1.594
2026	1.649	1.649	1.717	1.700
2027	1.685	1.685	1.753	1.736
2028	1.713	1.713	1.781	1.755
2029	1.737	1.737	1.814	1.796
2030	1.768	1.768	1.854	1.828
2031	1.812	1.812	1.889	1.863
2032	1.833	1.833	1.918	1.893
2033	1.865	1.865	1.950	1.924
2034	1.890	1.890	1.974	1.949
2035	1.931	1.931	2.016	1.990
2036	1.968	1.968	2.054	2.028
2037	1.998	1.998	2.083	2.058
2038	2.028	2.028	2.122	2.097
2039	2.067	2.067	2.162	2.127
2040	2.097	2.097	2.192	2.166
2041	2.140	2.140	2.243	2.209
2042	2.183	2.183	2.286	2.252
2043	2.226	2.226	2.329	2.295
2044	2.278	2.278	2.381	2.347
2045	2.321	2.321	2.424	2.389
2046	2.364	2.364	2.475	2.441
2047	2.415	2.415	2.518	2.484
2048	2.458	2.458	2.570	2.536
2049	2.507	2.507	2.621	2.586
2050	2.558	2.558	2.674	2.638
2051	2.609	2.609	2.727	2.691
2052	2.661	2.661	2.782	2.745
2053	2.714	2.714	2.837	2.800
2054	2.768	2.768	2.894	2.855
2055	2.824	2.824	2.952	2.913
2056	2.880	2.880	3.011	2.971
2057	2.938	2.938	3.071	3.030
2058	2.997	2.997	3.133	3.091
2059	3.057	3.057	3.195	3.153
2060	3.118	3.118	3.259	3.216
2061	3.180	3.180	3.325	3.280
2062	3.244	3.244	3.391	3.346
2063	3.308	3.308	3.459	3.413
2064	3.375	3.375	3.528	3.481
2065	3.442	3.442	3.599	3.550
2066	3.511	3.511	3.671	3.621
2067	3.581	3.581	3.744	3.694
2068	3.653	3.653	3.819	3.768
2069	3.726	3.726	3.895	3.843
2070	3.800	3.800	3.973	3.920

1 **Assumptions (Table F-3)**

- 2 • Price forecast reflects the delivered cost of No. 2 fuel specifications used by Hydro.
- 3 • Pricing excludes carbon taxation as per Government of Newfoundland and Labrador Carbon
- 4 Plan.
- 5 • Price forecast reflects existing fuel supply delivery methods. Price margins between Port Hope
- 6 Simpson and Mary's Harbour reflect historical fuel supply contract price margins. Price margins
- 7 between Port Hope Simpson and St. Lewis reflect existing fuel supply contract price margins.
- 8 • Basis for 2020–2040 price forecast is Platts Analytics high crude price outlook, May 2020 SPS
- 9 Long Term. Post-2040 price forecast reflects price inflation of 2%.
- 10 • High price projection does not consider possible US-CDN FX effects on fuel pricing that would
- 11 dampen price



Schedule 2

**Long-Term Supply for Southern Labrador
Evidence Supporting the Revised Application**



Long-Term Supply for Southern Labrador

Evidence Supporting the Revised Application



1 **Executive Summary**

2 On July 16, 2021, Newfoundland and Labrador Hydro (“Hydro”) filed its application for approval of
3 Phase 1 of Hydro’s long-term supply plan for southern Labrador (“Original Application”).¹ The Phase 1
4 proposal included the construction of a regional diesel generating station in Port Hope Simpson and
5 distribution infrastructure to interconnect the communities of Port Hope Simpson, Charlottetown, and
6 Pinsent’s Arm. Phases 2 and 3 of Hydro’s long-term plan supply plan for southern Labrador would see
7 the interconnection of the communities of Mary’s Harbour (including Lodge Bay, which is served on the
8 Mary’s Harbour Distribution System) and St. Lewis, respectively, coinciding with the expected
9 retirement dates for the diesel generating stations located in those communities in 2030 and 2045.
10 Upon completion in 2045, Hydro’s long-term supply plan for southern Labrador would see the
11 interconnection of four systems through the construction of the regional diesel generating station,
12 meeting Hydro’s mandate to provide safe, least-cost, environmentally responsible, and reliable power to
13 these six communities.

14 On April 7, 2022² and May 16, 2022,³ the Board of Commissioners of Public Utilities (“Board”) provided
15 correspondence to Hydro with respect to the Original Application. In its correspondence, the Board
16 requested that Hydro provide additional information and analysis to supplement the information that
17 had been filed. The correspondence also stated that Hydro should engage an independent expert to
18 assist in the analysis of the options and approach for the provision of service in southern Labrador.⁴
19 Hydro selected Midgard Consulting Inc. (“Midgard”) to carry out this analysis. The “Southern Labrador
20 Communities – Integrated Resource Plan” (“Midgard IRP”) was filed with the Board on March 31, 2023.⁵

21 As described in the Midgard IRP, Midgard’s analysis largely confirmed Hydro’s conclusions provided
22 within the Original Application, with the recommendation to proceed with the construction of a regional

¹ “Long-Term Supply for Southern Labrador – Phase 1,” Newfoundland and Labrador Hydro, July 16, 2021.

² “Newfoundland and Labrador Hydro - 2021 Capital Budget Supplemental Application Approval of the Construction of Phase 1 of Hydro’s Long-term Supply Plan for Southern Labrador - To NLH - Further Information Required Before Schedule is Resumed,” Board of Commissioners of Public Utilities, April 7, 2022.

³ “Newfoundland and Labrador Hydro - 2021 Capital Budget Supplemental Application Approval of the Construction of Phase 1 of Hydro’s Long-term Supply Plan for Southern Labrador – Response to Hydro’s Letter dated April 26, 2022,” Board of Commissioners of Public Utilities, May 16, 2022.

⁴ “Newfoundland and Labrador Hydro - 2021 Capital Budget Supplemental Application Approval of the Construction of Phase 1 of Hydro’s Long-term Supply Plan for Southern Labrador - To NLH - Further Information Required Before Schedule is Resumed,” Board of Commissioners of Public Utilities, April 7, 2022.

⁵ “Southern Labrador Communities - Integrated Resource Plan,” Midgard Consulting Inc., March 28, 2023.

1 diesel generating station and interconnection of the communities of southern Labrador—Charlottetown,
2 Pinsent’s Arm, Mary’s Harbour, Lodge Bay, Port Hope Simpson, and St. Lewis (“Southern Labrador
3 Communities”). Midgard’s recommendation differed from the proposal put forth in Hydro’s Original
4 Application in suggesting full, immediate interconnection of all six communities instead of using a
5 phased approach. Another difference is the recommendation to design the regional diesel generating
6 station with N-1 reliability, rather than designing conservatively with N-2 reliability as initially proposed
7 by Hydro.⁶ An N-1 reliability design is consistent with Hydro’s planning standards for its other isolated
8 systems and is consistent with good utility practice.

9 Hydro generally agreed with Midgard's recommendations and has adjusted the project scope, estimated
10 cost, and schedule accordingly. The revised total project cost is \$86.4 million, reflecting increases from
11 Hydro’s original proposal due to escalation and the additional distribution infrastructure. As a result of
12 increased equipment lead times, the estimated duration of the project has increased from three to four
13 years, with the regional diesel generating station and full interconnection expected to enter service in
14 2027, assuming project approval in the fall of 2023. Hydro will seek all opportunities to advance work
15 whenever practical.

16 Hydro believes a regional diesel generating station that interconnects the Southern Labrador
17 Communities is the appropriate least-cost solution to providing safe and reliable service to those
18 communities, based on the acceptance of Midgard's recommendations and the subsequent updates to
19 the project scope, estimated cost, and schedule. This evidence provided as Schedule 2, presents the
20 revised long-term supply plan for southern Labrador based on the acceptance of Midgard’s
21 recommendations and includes the regional diesel generating station as well as the advanced timeframe
22 for construction of additional distribution lines for full interconnection of all communities.

⁶ N-1 redundancy refers to the capacity to support full system load with the largest generating unit out of service. N-2 redundancy refers to the ability to serve full system load with the two largest generating units out of service.

Contents

Executive Summary.....	i
1.0 Introduction	1
2.0 Background	2
2.1 Original Application.....	2
3.0 The Midgard IRP.....	4
3.1 Analysis of Alternatives.....	4
3.2 Requirement for Backup Generation.....	5
3.3 Reliability.....	6
3.4 Integration of Renewables.....	6
3.5 Demand-Side Management.....	6
3.6 Alternative Fuels	7
3.7 Recommendations	7
3.7.1 Proceed with Regional Diesel Generating Station and Advance Full Interconnection.....	7
3.7.2 Minimize Future Reliance on Mobile Gensets for Base Load	8
3.7.3 Design Regional Diesel Generating Station for N-1 Reliability.....	8
3.7.4 Support and Procure Incremental Low-Cost Renewable Energy.....	9
3.7.5 Consider a Deeper Study of Customer Demand Management	10
3.7.6 Evaluate New Technologies	10
4.0 Project Description.....	10
4.1 Impact to Project Scope	11
4.1.1 Regional Diesel Generating Station	11
4.1.2 Distribution Infrastructure	12
4.2 Impact to Project Cost Estimate	13
4.3 Revenue Requirement Impact	14
4.4 Impact on Project Schedule	16
5.0 Stakeholder Consultations	17
6.0 Conclusion.....	18

1.0 Introduction

Hydro filed its Original Application for approval of the construction of Phase 1 of its long-term supply plan for southern Labrador on July 16, 2021. Hydro proposed the construction of a regional diesel generating station located in Port Hope Simpson and distribution infrastructure to interconnect the communities of Port Hope Simpson, Charlottetown, and Pinsent’s Arm. Phases 2 and 3 of Hydro’s long-term supply plan for southern Labrador would see the interconnection of the communities of Mary’s Harbour (including Lodge Bay, which is served on the Mary’s Harbour Distribution System) and St. Lewis, respectively, coinciding with the expected retirement dates for the diesel generating stations located in those communities in 2030 and 2045.

The Board’s subsequent correspondence, on April 7, 2022 and May 16, 2022, requested that Hydro provide additional information and analysis to supplement the information provided in the Original Application and stated that Hydro should engage an independent expert to assist in the analysis of the options and approach for the provision of service in southern Labrador. On June 22, 2022, Hydro met with Board staff to review the scope of work Hydro proposed would form the basis of a request for proposal (“RFP”) to identify and retain a consultant to carry out the independent analysis requested by the Board. Hydro subsequently issued the RFP and selected Midgard to carry out this analysis.

On March 28, 2023, Hydro received the Midgard IRP, which largely confirmed the conclusions of Hydro’s study.⁷ The Midgard IRP recommended to proceed with the construction of a regional diesel generating station and interconnection of the Southern Labrador Communities, based on the conclusion that interconnection is the most cost-effective and reliable solution for the provision of service to these communities. As described in the Midgard IRP, six recommendations were provided by Midgard for consideration, including:

- 1) The least-cost alternative for Hydro to reliably serve the region is to proceed with the regional diesel generating station to an N-1 planning standard with immediate interconnection of all four systems, upgraded to 25 kV, instead of the phased approach proposed in the Original Application.

⁷ “Long-Term Supply for Southern Labrador – Phase 1,” Newfoundland and Labrador Hydro, July 16, 2021, sch. 1.

- 1 **2)** Hydro should minimize future reliance on mobile gensets to supply base load energy and
2 capacity.⁸
- 3 **3)** Hydro should design the regional diesel generating station with N-1 redundancy, instead of N-2
4 as proposed in the Original Application.
- 5 **4)** Hydro should continue to support and procure incremental low-cost renewable energy through
6 power purchase agreement (“PPA”) partnerships with community and Indigenous partners.
- 7 **5)** Hydro should study opportunities for further customer demand management, such as the
8 conversion of resistive electric heat to high-efficiency heat pumps.
- 9 **6)** While renewable energy technologies are not currently technically or economically feasible for
10 the provision of firm capacity, it is recommended that Hydro evaluate new technologies as
11 diesel units come due for replacement.⁹

12 Following its review of the Midgard IRP, Hydro accepted the recommendations provided. Schedule 2
13 provides an overview of the proposed recommendations, support for Hydro’s acceptance of Midgard’s
14 recommendations, and details changes in the project scope, estimated cost, and schedule since the
15 Original Application.

16 Since 2021, Hydro has experienced cost pressures and increased equipment lead times due to
17 heightened inflation and global supply chain constraints; the associated impacts on project cost and
18 schedule are discussed and reflected herein.

19 **2.0 Background**

20 **2.1 Original Application**

21 Hydro’s Original Application sought approval for the construction of Phase 1 of Hydro’s long-term supply
22 plan for southern Labrador at an estimated cost of \$49.9 million. The scope of Phase 1 of the long-term
23 supply plan, planned for commissioning in 2024, included:

- 24
 - The construction of a regional diesel generating station in Port Hope Simpson;

⁸ An engine coupled with an electric generator is referred to as a “genset.”

⁹ Installed capacity refers to the total installed generation capacity whereas firm capacity refers to the total installed capacity without the largest unit in service.

- 1 • The construction of 53 kilometres of 25 kV distribution lines interconnecting the communities of
2 Port Hope Simpson, Charlottetown, and Pinsent’s Arm to the regional diesel generating station;
3 and
- 4 • 25 kV voltage conversion of the Port Hope Simpson and Charlottetown Distribution Systems, the
5 latter of which serves the communities of Charlottetown and Pinsent’s Arm.

6 The scope of Phase 2, planned for commissioning in 2030 at an estimated cost of \$15.2 million, included:

- 7 • The addition of one 1,800 kW genset at the regional diesel generating station in Port Hope
8 Simpson;
- 9 • The construction of an additional 50 kilometres of 25 kV distribution line interconnecting the
10 communities of Mary’s Harbour and Lodge Bay; and
- 11 • 25 kV voltage conversion of the Mary’s Harbour Distribution System, which serves the
12 communities of Mary’s Harbour and Lodge Bay.

13 The scope of Phase 3, planned for commissioning in 2045 at an estimated cost of \$7.5 million, included:

- 14 • The construction of a 30 kilometre distribution line interconnecting the St. Lewis Distribution
15 System to the regional diesel generating station in Port Hope Simpson; and
- 16 • 25 kV voltage conversion of the St. Lewis Distribution System.

17 The proposed regional diesel generating station would be designed with six engine bays,¹⁰ four of which
18 would be in use in Phase 1 and the fifth utilized for the addition of one genset in Phase 2. The sixth
19 engine bay would be reserved to accommodate potential future load growth.

20 Hydro’s analysis included the proposed phased approach to interconnection, as well as an alternative
21 that would see the full interconnection of the four southern Labrador systems at once. Hydro’s analysis
22 determined that these alternatives were equivalent from a net present value perspective. Hydro opted
23 to propose the phased interconnection to allow for flexibility in the timing of future phases. Table 1
24 outlines the interconnection costs by phase from the Original Application.

¹⁰ The engine bay is the space inside the diesel generating station reserved for the installation of a genset.

Table 1: 2021 Interconnection Costs by Phase (\$ Millions)

Project Phase	In-Service Year	Capital Costs (2021 Estimate)
Phase 1	2024	49.9
Phase 2	2030	15.2
Phase 3	2045	7.5
	Total	72.6

1 In its analysis, Hydro assessed the expected reliability impacts of the studied alternatives for each
2 system. Based on this analysis, Hydro proposed that the regional diesel generating station be designed
3 to an N-2 reliability standard, to ensure that the interconnected system would provide the same or
4 better reliability than the status quo. Hydro estimated that N-2 redundancy would provide an 18%
5 improvement in both all-cause unavailability and a reduction in expected unserved energy.¹¹

6 **3.0 The Midgard IRP**

7 Midgard made a number of findings and recommendations that relate to the concerns outlined by the
8 Board. A summary of these findings and recommendations follows.

9 **3.1 Analysis of Alternatives**

10 Midgard evaluated numerous alternative long-term supply solutions for southern Labrador. It
11 considered the viability of ten different resource technologies, the practicality of using Battery Energy
12 Storage Systems as a source of firm capacity, and numerous detailed alternatives based on eight base
13 scenarios and multiple sub-variations to account for different reliability criteria, development timing,
14 and other factors. The scenarios aimed to satisfy three supply criteria—capacity, energy, and reliable
15 backup. The alternatives that were considered ranged from refurbishing existing stations and
16 maintaining isolated community services to constructing new regional generating stations (thermal or
17 hydraulic) with full interconnections and voltage conversions or interconnection with the Labrador
18 Interconnected System.

19 Midgard acknowledged that intermittent renewable energy sources, such as wind and solar generation,
20 might be viable for the provision of energy; however, to provide firm capacity, intermittent resources
21 must be paired with energy storage with the capacity to supply the system for several days in the event
22 of low renewable generation. Regarding the future cost-effectiveness of Battery Energy Storage

¹¹ All-cause unavailability refers to unavailability caused by generation- or distribution-related outages.

1 Systems, Midgard concluded that renewable energy sources with sufficient battery storage to provide
2 firm capacity remains cost-prohibitive at this time. The Midgard IRP indicated that based on the most
3 optimistic projections, battery prices may drop by up to 70% over the next 25 years, with the largest
4 price drops expected in the next 10 years being approximately 55%. Despite these potential price
5 reductions, Midgard concluded that it is unlikely for renewable systems with Battery Energy Storage
6 Systems to become cost-competitive with thermal generation systems within the next decade.

7 The Midgard IRP highlighted several benefits of interconnecting the Southern Labrador Communities to
8 a regional generating station, including operational savings due to reduced fuel consumption, improved
9 system reliability, reduced capital costs, and greater potential for renewable penetration. Midgard
10 noted that the interconnected system would allow for greater penetration of renewable energy and
11 therefore greater opportunity to offset diesel fuel usage. Midgard also found that proceeding with the
12 full interconnection, rather than phased interconnection, is more cost-effective and will likely enable
13 greater renewable penetration sooner.

14 Midgard noted that the use of diesel gensets in Hydro's proposed approach is consistent with practices
15 in other similar jurisdictions across Canada. Diesel generation remains a common solution for remote
16 communities due to its reliability, ease of installation, and cost-effectiveness. Midgard's analysis of
17 similar jurisdictions provides context for the proposed approach and supports its suitability for the
18 southern Labrador system.

19 Midgard conducted a cost-benefit analysis considering both direct costs, such as capital investments and
20 operational expenses, and indirect costs, such as environmental impacts and potential economic
21 benefits. Midgard also carried out a sensitivity analysis considering the impacts of ten variables,
22 including carbon and diesel fuel costs. Midgard's analysis suggested that the upfront capital costs of
23 interconnecting the four systems and six communities would be offset by operational savings over a 25-
24 year period, which is consistent with Hydro's Original Application.

25 **3.2 Requirement for Backup Generation**

26 Midgard's assessment emphasized the importance of maintaining reliable backup generation to ensure
27 the continuous supply of electricity for the Southern Labrador Communities should regional or
28 community-based renewable energy solutions advance or a larger interconnection to the Labrador
29 Interconnected System come to fruition. Regardless of the alternative chosen, Midgard notes that a

1 dependable capacity resource, such as diesel gensets, is required to provide capacity and energy during
2 emergencies or periods of high demand.

3 **3.3 Reliability**

4 Based on its findings, Midgard noted that an N-2 planning standard provides marginal benefits in overall
5 customer reliability and may not warrant the additional cost.¹² Midgard recommends immediate
6 construction of a regional diesel generating station to an N-1 planning standard, interconnecting all four
7 systems and upgrading to 25 kV service in each community.

8 **3.4 Integration of Renewables**

9 Midgard recommends that Hydro pursue PPAs, particularly through partnerships with Indigenous
10 stakeholders, to integrate renewable energy sources into the system. This approach will help offset
11 diesel fuel usage, reduce greenhouse gas emissions, and provide potential economic benefits to the
12 communities. By considering a different amount of displaced energy (25% to 50%) from renewables
13 depending on the scenario, Midgard acknowledges the role of renewable energy in enhancing the
14 overall sustainability of fossil fuel alternatives. Midgard emphasizes the importance of Indigenous and
15 community involvement in renewable energy projects and recommends that Hydro actively support and
16 engage Indigenous groups in the procurement of renewable energy supplies. This approach aligns with
17 federal policies that favor Indigenous-led development of renewable energy projects, contributing to
18 the growth of Indigenous communities and fostering a more inclusive energy sector.

19 **3.5 Demand-Side Management**

20 Midgard assessed the viability of demand-side management (“DSM”) for load reduction in southern
21 Labrador. It concluded that, while there may be opportunities for further demand reduction, DSM is
22 unlikely to be effective in eliminating the need for additional firm capacity in southern Labrador, as
23 Hydro has already availed of most opportunities to incentivize energy efficiency and manage customer
24 demand. Midgard notes that by interconnecting multiple communities with non-concurrent peak loads,
25 Hydro will be able to avail of many of the benefits typically achieved through DSM. Midgard notes that
26 DSM may improve the ability to accommodate load growth. Midgard does note that there may be
27 limited potential for load reduction through conversion from resistive electric heat to heat pumps;

¹² Expected unserved energy for N-1 planning criteria is estimated to be 33 MWh, or 0.2% of energy served, compared to 18 MWh for N-2 redundancy.

1 however, Midgard notes that care must be taken to not incentivize conversion from other fuel sources
2 to electric heating.

3 Midgard’s recommendation is that Hydro undertakes further study in this regard.

4 **3.6 Alternative Fuels**

5 Midgard assessed options such as compressed natural gas, liquefied natural gas, biodiesel, and
6 hydrogen. It concluded that these alternatives are not currently cost-effective for the southern Labrador
7 diesel generation systems. Midgard also noted that alternative fuels might present technical or logistical
8 challenges, such as cold weather performance, that preclude their use at this time. However, Midgard
9 notes that Hydro should continue to monitor developments in these areas as emerging technologies
10 may become more favorable in the future. Hydro notes that a regional diesel generating station would
11 not preclude it from availing of alternative fuels, should they become technically and economically
12 feasible in the future.

13 **3.7 Recommendations**

14 The recommendations made by Midgard for Hydro’s consideration follow.

15 **3.7.1 Proceed with Regional Diesel Generating Station and Advance Full** 16 **Interconnection**

17 Midgard determined that interconnection of the Southern Labrador Communities with a regional diesel
18 generating station is the least-cost alternative to reliably serve the region. Midgard concluded that
19 immediate interconnection is lower cost, on a cumulative present worth basis, than the originally
20 proposed phased interconnection for the following reasons:

1. Time has passed since the prior analysis was completed and the planned replacement of the MSH^[13] plant is closer than when initially modelled. This reduces any cost benefit attributable to deferral of those costs.
2. Further unplanned deterioration of the plant at MSH necessitates material capital spending to extend the life of that facility through to 2030.

¹³ Mary’s Harbour (“MSH”).

3. Increased forecast diesel costs favour scenarios with higher efficiency, such as a regional plant, and increased renewable procurement. The fully interconnected system configuration facilitates increased penetration of incremental renewable energy resources.¹⁴

1 Following a review of Midgard’s analysis, Hydro accepts Midgard’s recommendation to advance the
2 interconnection of all four systems in southern Labrador and to construct a regional diesel generating
3 station. Hydro notes that Midgard’s recommendation is consistent with Hydro’s legislated mandate to
4 provide reliable service at least-cost, in an environmentally responsible manner. Hydro also notes that
5 the Government of Canada has engaged stakeholders as part of its process to develop the forthcoming
6 Clean Electricity Regulations; through this engagement, the Government of Canada has acknowledged
7 that available technologies do not enable the transition to fully renewable power systems in isolated
8 communities and these systems are therefore expected to be exempt from the standard. The regional
9 diesel generating station provides base-load power to ensure reliable service while enabling the
10 integration of intermittent renewable resources or the interconnection to the Labrador Interconnected
11 System, should such an interconnection become viable in the future. Any potential additional execution
12 risk associated with undertaking the regional interconnection at this time will be offset by the economic
13 benefits associated with interconnection.

14 **3.7.2 Minimize Future Reliance on Mobile Gensets for Base Load**

15 Midgard notes that mobile gensets are not suitable for permanent base-load application, given their
16 lower reliability than fixed diesel generating units, and recommends that Hydro not rely on mobile
17 gensets as a planning resource for base load. Hydro accepts Midgard’s recommendation, noting that
18 following the construction of the regional diesel generating station, it would no longer rely on mobile
19 gensets to supply base load in Charlottetown or Mary’s Harbour. Customers previously served by the
20 Charlottetown Diesel Generating Station are currently served by mobile gensets—a temporary
21 configuration and interim solution due to an October 2019 fire that left the Charlottetown Diesel
22 Generating Station inoperable.

23 **3.7.3 Design Regional Diesel Generating Station for N-1 Reliability**

24 Midgard analyzed the expected benefits of designing the regional diesel generating station to an N-2
25 standard rather than N-1, Hydro’s standard redundancy criteria for diesel generating stations. Midgard

¹⁴ “Southern Labrador Communities - Integrated Resource Plan,” Midgard Consulting Inc., March 28, 2023, sec. 7.4, p. 85/3–10.

1 notes that, while N-2 provides marginal reliability benefits, it is Midgard’s opinion that the marginal
2 improvement in reliability does not merit the cost required to achieve this standard. Therefore, Midgard
3 recommends that Hydro design the regional diesel generating station with N-1 redundancy, with
4 reference to the suggestion that Hydro’s mobile diesel unit fleet could be utilized to provide redundancy
5 in the event of a unit failure at the regional diesel generating station.

6 Hydro has accepted Midgard’s recommendations regarding generating unit redundancy and has revised
7 the design of the regional diesel generating station to N-1 redundancy. Hydro decided to retain the
8 regional diesel generating station footprint as originally proposed, with the additional engine bay
9 available to establish N-2 redundancy if required. This approach ensures that the regional diesel
10 generating station meets standard redundancy criteria while providing the option for N-2 redundancy if
11 necessary in the future. Hydro will monitor the reliability of the interconnected system to determine if
12 N-2 redundancy is required to ensure reliable service.

13 **3.7.4 Support and Procure Incremental Low-Cost Renewable Energy**

14 Midgard recommends that Hydro continue to support and procure incremental low-cost renewable
15 energy through PPAs with community and Indigenous partners to offset diesel fuel usage therefore
16 reducing emissions and costs. Midgard notes that Hydro’s existing approach to PPA partnerships is likely
17 to provide favourable economics for such community-led projects, made even more economically viable
18 through newly announced federal programs.¹⁵

19 Hydro notes that Midgard’s recommendations regarding the support and procurement of low-cost
20 renewable energy is consistent with Hydro’s current practices and has been successfully implemented
21 on other isolated systems. Hydro is committed to continuing to work with its community and Indigenous
22 partners to support the development of renewable energy sources and maximize the penetration of
23 renewable energy on the interconnected system.

¹⁵ “Budget 2023: A Made-in-Canada Plan: Strong Middle Class, Affordable Economy, Healthy Future,” Government of Canada, March 28, 2023.

3.7.5 Consider a Deeper Study of Customer Demand Management

Midgard notes that while Hydro has availed of most of the opportunities to manage customer demand and incentivize energy efficiency, Hydro should continue to study opportunities for further customer demand management, such as the conversion of resistive electric heat to high-efficiency heat pumps.

Hydro notes that since 2021, it has implemented pilot programs assessing the viability of cold-climate heat pumps and shifted energy technology for demand management. These ongoing pilot programs will provide Hydro with the data to inform a decision regarding the broader implementation of the programs. Additionally, Hydro will continue to work with community stakeholders to explore the use of alternative fuels, such as wood heat, to offset electricity usage on isolated systems. Hydro is also exploring other DSM initiatives for future consideration, such as commercial energy audits.

3.7.6 Evaluate New Technologies

Midgard notes that while renewable energy technologies are not currently technically or economically feasible for the provision of firm capacity, Hydro should evaluate new technologies as diesel units come due for replacement.

Hydro has accepted this recommendation and will evaluate available technologies as diesel units come due for replacement. Hydro notes that the construction of the regional diesel generating station does not preclude it from availing of new technologies in the future.

4.0 Project Description

Following Hydro’s review of the recommendations provided by Midgard, impacts to the project scope, cost estimate, and schedule provided in Hydro’s Original Application are summarized in Table 2.

Table 2: Key Revisions between Original Application and Revised Application

Application	Interconnection	Redundancy	Cost (\$ Millions)	Schedule Closeout
Original (2021)	Phased Approach	N-2	49.9 (Phase 1)	Fourth Quarter 2024 (Phase 1)
Revised (2023)	Full	N-1	86.4 (Full)	Third Quarter 2027 (Full)

1 **4.1 Impact to Project Scope**

2 **4.1.1 Regional Diesel Generating Station**

3 Hydro's Original Application for Phase 1 of its long-term supply plan for southern Labrador included the
4 construction of a regional diesel generating station designed with N-2 redundancy. In Phase 1, Hydro
5 proposed to equip this generating station with four diesel units and would have two additional engine
6 bays—one for an additional unit to be installed in Phase 2 and the other to accommodate load growth.
7 Hydro's acceptance of Midgard's recommendations has no net impact on the design of the regional
8 diesel generating station.

9 The new regional diesel generating station will be constructed on land owned by Hydro adjacent to the
10 existing diesel generating station in Port Hope Simpson. The site will contain a fuel storage area,
11 powerhouse, switchyard, laydown area, septic system, water well, access roads, and a perimeter fence.
12 The fuel storage area will include two 80,000 L and two 60,000 L double-walled horizontal tanks (total
13 storage 280,000 L).¹⁶ The powerhouse will be a single-story building of steel and concrete construction,
14 with a mezzanine housing the control room, office, kitchenette, and washrooms. The ground floor will
15 contain the engine hall, electrical/motor control center room, battery room, mechanical room, fire
16 suppression room, and fuel storage room. The building will have fire and sound separations between the
17 engine room, battery room, fuel storage room, and other areas; the building will mainly be heated by a
18 heat recovery system from the generating units. The control room/office area and electrical/motor
19 control center room will be cooled with split system air conditioning units and the engine room will be
20 cooled with mechanical ventilation. An overhead crane will be located in the engine hall to support
21 maintenance activities. Generating units will have remote radiators and exhaust stacks.

22 The 25 kV substation yard in Port Hope Simpson will include two 5 MVA 25 kV/4.16 kV transformers, oil
23 containment, a wood pole structure supporting reclosers, motorized disconnect switches, a 25 kV
24 tension bus, yard lighting, and a 300 kVA 25-0.6 kV station service transformer bank. Unit switchgear,
25 remote unit protection and control panels, black start panel, uninterruptible power supply, battery
26 chargers, and arc-rated motor control centers will be located within the electrical room. Power cables

¹⁶ The two 60,000 L tanks are existing tanks that were recently installed at the Charlottetown Diesel Generating Station and will be relocated for use at Port Hope Simpson.

1 from the generating units to switchgear will be in floor trenches, will travel overhead from the
2 switchgear to the exterior powerhouse wall, and will continue to each transformer in trenches.

3 While the scope change from N-2 to N-1 redundancy results in one less unit required for the regional
4 diesel generating station, an additional unit is required for the immediate connection of all
5 communities, which was originally planned for Phase 2. As a result, Hydro will maintain the initial design
6 plan for the regional diesel generating station with six engine bays, to ensure sufficient footprint to
7 accommodate future load growth, and to allow for N-2 redundancy if deemed necessary. While the
8 provision of an extra engine bay to accommodate N-2 redundancy has an incremental cost of
9 approximately \$700,000, this is significantly less than the cost of expanding the building footprint in the
10 event that an additional engine bay is required. Hydro notes that this additional footprint could also be
11 utilized for equipment to support the integration of renewable energy or storage technologies in the
12 future. The installed capacity for the regional diesel generating station will be approximately 6,300 kW,
13 derived from four gensets of the following general sizes: (i) one 1,200 kW unit, (ii) one 1,500 kW unit,
14 and (iii) two 1,800 kW units. This would translate into a firm capacity of 4,500 kW, which can
15 accommodate the forecasted peak demand of all Southern Labrador Communities, as shown in Hydro's
16 Original Application. Sizing of the gensets varied slightly since Hydro's Original Application based on
17 updated information from Hydro's Long-Term Asset Planning group; however, this change does not
18 account for a significant price increase.

19 **4.1.2 Distribution Infrastructure**

20 Hydro's Original Application included the construction of 53 kilometres of 25 kV distribution lines
21 interconnecting the communities of Charlottetown, Pinsent's Arm, and Port Hope Simpson and 25 kV
22 voltage conversion in those communities. There is no change to these proposed distribution lines. The
23 25 kV interconnection will include the construction of a new 25 kV distribution line, comprised of
24 477 aluminum-stranded conductors, along highway Routes 510 and 514 between Port Hope Simpson
25 and Charlottetown. A short segment of 25 kV line will also be constructed to connect to the existing
26 distribution system in Port Hope Simpson. In addition, a fibre optic line will be installed for
27 communication purposes. Also included are 25 kV voltage conversions for the existing distribution
28 systems in each community and the installation of a 200 A voltage regulator at the Charlottetown end of
29 the 25 kV interconnection.

1 With Hydro’s acceptance of Midgard’s recommendation to advance the full interconnection of all
 2 communities, the project scope (originally planned for Phases 2 and 3) now also includes the
 3 construction of an additional 80 kilometres of 25 kV distribution lines interconnecting the communities
 4 of Mary’s Harbour, Lodge Bay, and St. Lewis and 25 kV voltage conversion in those communities.

5 **4.2 Impact to Project Cost Estimate**

6 Hydro’s Original Application sought approval of the construction of Phase 1 of its long-term supply plan
 7 for southern Labrador to be completed in 2024 at an estimated cost of \$49.9 million. Since this time,
 8 escalation has resulted in an estimated cost increase for the original project scope of approximately
 9 \$14.1 million. This cost increase is primarily due to inflationary pressures on the cost of labour and
 10 materials as well as increases in material lead times resulting in a longer project duration and interest
 11 period during construction.

12 The additional distribution infrastructure and the fourth genset associated with the advancement of the
 13 full interconnection of all Southern Labrador Communities results in a further cost increase of
 14 approximately \$22.4 million, bringing the project total to \$86.4 million, as outlined in Chart 1. Hydro’s
 15 revised project estimate is provided in Table 3.

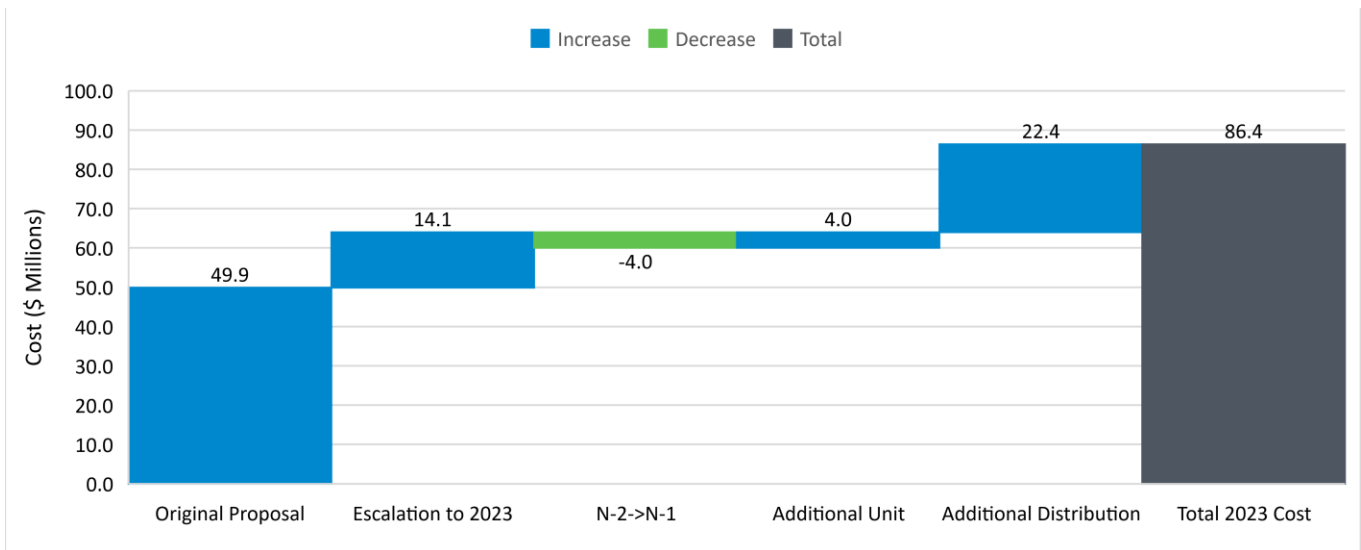

Chart 1: Cost Changes from 2021 Proposal to 2023

Table 3: Project Estimate (\$000)¹⁷

Project Cost	Previous	2023	2024	2025	2026	2027	Total
Material Supply	0.0	2.1	1,728.3	15,700.4	13,065.7	1,042.4	31,538.7
Labour	0.0	1,053.7	1,868.9	1,959.3	702.7	414.0	5,998.5
Consultant	0.0	538.5	1,871.1	996.2	776.5	287.3	4,469.6
Contract Work	0.0	0.0	8,663.4	13,360.9	3,573.9	226.8	25,825.0
Other Direct Costs	0.0	73.0	1,161.6	2,232.0	606.2	119.5	4,192.3
Interest and Escalation	0.0	46.2	758.8	2,363.5	2,742.1	998.9	6,909.5
Contingency	0.0	121.2	1,759.6	3,504.0	1,860.5	215.2	7,460.5
Total	0.0	1,834.7	17,811.7	40,116.3	23,327.4	3,304.1	86,394.2

1 4.3 Revenue Requirement Impact

2 Hydro has forecasted the net impact of the selected alternative to its revenue requirement in
 3 comparison to the reconstruction of the Charlottetown Diesel Generating Station with continued
 4 operation as isolated systems. Compared to the isolated systems option, the interconnection of the
 5 Southern Labrador Communities is expected to generate an incremental revenue requirement increase
 6 of \$2.3 million in 2030, due to higher upfront capital costs. As a result of decreased operating,
 7 maintenance, fuel, and sustaining capital costs, Hydro forecasts a reduction in net incremental revenue
 8 requirements of \$1.1 million in 2035 and \$6.2 million by 2050.¹⁸ The incremental revenue requirement
 9 impacts for the interconnected system supplied by a regional diesel generating station compared to
 10 isolated systems served by individual plants are presented in Chart 2.

¹⁷ Numbers may not add due to rounding.

¹⁸ Hydro’s insurance claim relating to the 2019 fire at the Charlottetown Diesel Generating Station is ongoing. Should this claim result in a payment to Hydro, such payment will be applied to reduce the revenue requirement associated with this project.

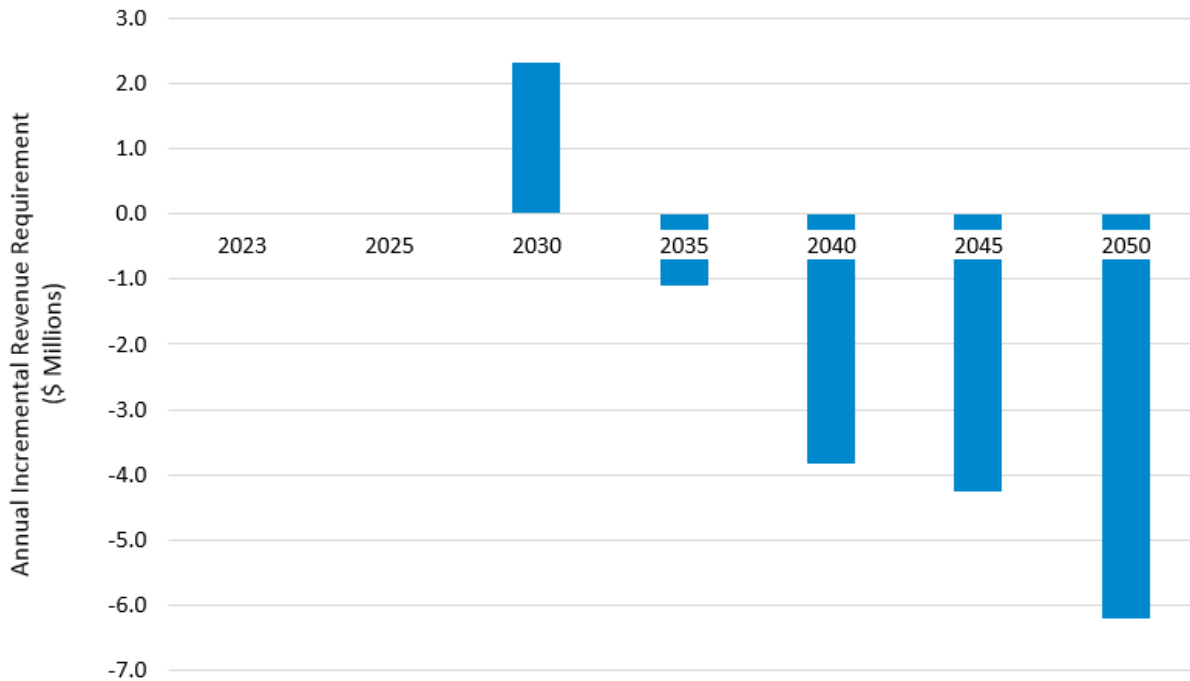

Chart 2: Incremental Revenue Requirements for Interconnection vs Isolated

1 Forecast rate impacts associated with changes in the incremental revenue requirements are presented
 2 in Table 4. The forecast is in comparison to the 2019 Test Year and assumes the incremental revenue
 3 requirements will be shared between Newfoundland Power Inc. and Rural Labrador Interconnected
 4 customers in the same proportion in which the rural deficit was allocated in the 2019 Cost of Service
 5 Study.¹⁹

Table 4: Forecast Incremental Rate Impacts (%)²⁰

Impact on Revenue Requirement	2030	2035	2040	2045	2050
Newfoundland Power	0.3%	-0.2%	-0.6%	-0.6%	-0.9%
End Consumer ¹	0.2%	-0.1%	-0.4%	-0.4%	-0.6%
Labrador Interconnected	0.3%	-0.2%	-0.5%	-0.6%	-0.9%

¹⁹ Newfoundland Power 96.1% and Rural Labrador Interconnected 3.9%.

²⁰ The forecast rate impact of the total project is approximately 1.5% for the end consumer on the Island Interconnect System and 2.0% for consumers on the Labrador Interconnected System. Assumes the average revenue to cost ratio for customers on the Labrador Isolated System in the 2019 Test Year is 24%, which represents their portion of costs recovered through rates.

1 The interconnection of the southern Labrador distribution systems and implementation of a regional
 2 diesel generating station is expected to facilitate the potential future integration and penetration of
 3 renewable energy versus an approach that features individual isolated systems. Should any such
 4 opportunities arise in the future, it is anticipated that such integration could produce further reduction
 5 in revenue requirements due to decreased fuel and maintenance costs.

6 **4.4 Impact on Project Schedule**

7 As a result of increased material lead times, the estimated duration of the project has increased from
 8 three to four years. Assuming project approval in the fall of 2023, Hydro estimates that the operation of
 9 the regional diesel generating station and full interconnection of all six communities will enter service in
 10 2027.²¹ Hydro understands the importance and urgency of this project and has therefore proposed an
 11 aggressive schedule for project execution. Hydro acknowledges that this schedule may be impacted by
 12 external factors, such as regulatory and environmental approval and equipment lead times; however,
 13 Hydro will make every reasonable effort to expedite project completion.

14 The anticipated project schedule is shown in Table 5.

Table 5: Project Schedule

Activity	Start Date	End Date
Planning:		
Front-end engineering and project approval	First Quarter 2020	Third Quarter 2023
Environmental assessment	Third Quarter 2023	Second Quarter 2024
Design:		
Detailed design of diesel generating station and distribution	Third Quarter 2023	Fourth Quarter 2024
Procurement:		
Major equipment and construction contracts	Third Quarter 2023	Second Quarter 2026
Construction:		
Regional diesel generating station and distribution	Second Quarter 2024	First Quarter 2027
Commissioning:		
Commissioning of equipment	Fourth Quarter 2026	Second Quarter 2027
Closeout:		
Contract and project closeout	Second Quarter 2027	Third Quarter 2027

²¹ This schedule requires environmental approval by mid-2024. Hydro is investigating opportunities to initiate portions of the environmental assessment process as quickly as possible in order to meet this timeline.

5.0 Stakeholder Consultations

Following its receipt, Hydro shared the Midgard IRP with the Southern Labrador Communities and offered to meet to discuss the intended path forward. To date, Hydro has met with community representatives in Charlottetown and Pinsent’s Arm as well as Mary’s Harbour, Port Hope Simpson, and St. Lewis; the NunatuKavut Community Council (“NCC”); the Minister of Labrador Affairs; the Minister Responsible for Indigenous Affairs and Reconciliation; and the Member of the House of Assembly for the region. Hydro will continue to inform and consult with these stakeholders throughout the approval and execution process. Hydro is also committed to working with the NCC to ensure Hydro has met its Duty to Consult. Hydro has met with the NCC over the course of the regulatory process to share information. During these meetings, the NCC has expressed that they will not support the application based on the information provided and discussions to date.

Hydro will consult with the NCC as part of the Environmental Assessment process to address its stated concerns. These concerns include the integration of renewable sources in southern Labrador to ensure that the solution is environmentally responsible, as well as commercial considerations for the NCC relating to construction, ownership, and benefits associated with Hydro projects such as the proposed Southern Labrador Interconnection. Hydro is committed to working with the NCC to enable them to develop and maximize renewable sources of supply in southern Labrador. Hydro is also committed to supporting the advancement of NCC initiatives that align with Hydro’s mandate to provide power at the lowest possible cost, in an environmentally responsible manner, consistent with reliable service.

Hydro notes that a number of other towns have expressed opposition to the use of diesel generation and would prefer solutions involving a transmission interconnection. Customers in these communities are concerned with isolated rates that are prohibitive to electricity-based home heating. They also expressed frustration that Island customers can avail of renewable generation from Labrador but they do not have this option. Further, they presented perspectives that a transmission interconnection would be the preferred solution from an environmental standpoint.

Both Hydro and Midgard have assessed the use of renewable energy sources for the provision of firm capacity on isolated systems and have each concluded that transmission connections to interconnected systems do not meet the criteria of least cost. Additionally, due to the distance (over 400 kilometres) of the line required to interconnect the Southern Labrador Communities with the Labrador Interconnected System, backup generation would be required in the form of diesel generation. Finally, renewable

1 energy resources with Battery Energy Storage Systems are technically and economically prohibitive and
2 are expected to remain so for the foreseeable future. The use of diesel generation remains the only
3 viable solution that is consistent with Hydro’s legislated mandate. Full regional interconnection enables
4 Hydro to ensure that power is being provided in an environmentally responsible manner in addition to
5 least-cost, reliable service. While the regional diesel generating station and the firm capacity it provides
6 is necessary to ensure reliable service for the region, Hydro is fully committed to fostering and
7 supporting the development of renewable energy projects in the region to enable a reduction in diesel
8 fuel usage in partnership with its community and Indigenous partners.

9 **6.0 Conclusion**

10 In July 2021, Hydro proposed Phase 1 of its long-term supply plan for southern Labrador, which included
11 the construction of a regional diesel generating station and the interconnection of the communities of
12 Charlottetown, Pinsent’s Arm, and Port Hope Simpson, with the interconnection of Mary’s Harbour
13 (including Lodge Bay, which is served on the Mary’s Harbour Distribution System) and St. Lewis to follow
14 in Phases 2 and 3, respectively. In response to the Board’s direction for Hydro to provide additional
15 information and analysis to supplement the information that has been filed and engage an independent
16 expert to assist in the analysis, Hydro selected Midgard to complete an independent assessment of
17 Hydro’s plan and develop an integrated resource plan for the region. The Midgard IRP recommended
18 that Hydro proceed with its plan to construct a regional diesel generating station, albeit with scope
19 changes to design with N-1 redundancy and advancement of the interconnection of Mary’s Harbour and
20 St. Lewis. Hydro has accepted Midgard’s recommendations and has revised its project scope, estimated
21 cost, and schedule accordingly to reflect the passage of time since its Original Application and its
22 support of Midgard’s recommendations.

23 Hydro believes its revised proposal to construct a regional diesel generating station and interconnect
24 the Southern Labrador Communities meets Hydro’s mandate to provide power at the lowest possible
25 cost, in an environmentally responsible manner, consistent with reliable service.

Schedule 3

Long-Term Supply for Southern Labrador
Cost and Schedule Update



Long-Term Supply for Southern Labrador

Cost and Schedule Update



Contents

1.0	Introduction	1
1.1	Updated Project Estimate	1
1.2	Revenue Requirement Impact	1
1.3	Impact on Project Schedule	3

1.0 Introduction

On October 5, 2023, Newfoundland and Labrador Hydro (“Hydro”) filed additional information in relation to the application for long-term supply for southern Labrador, indicating that the in-service date for the proposed regional plant has shifted to 2028. Hydro notes that this shift in project schedule has resulted in marginal cost increases in the project estimate; the updated estimate and project schedule as well as impact on Hydro’s revenue requirements is provided within this report.

1.1 Updated Project Estimate

The updated project estimate is provided in Table 1.

Table 1: Project Estimate (\$000)¹

Project Cost	2023	2024	2025	2026	2027	2028	Total
Material Supply	0.0	0.0	1,158.4	15,311.1	11,874.2	3,195.0	31,538.7
Labour	914.1	634.7	1,886.2	1,798.5	985.6	219.5	6,438.6
Consultant	0.0	1,484.3	1,040.4	961.4	658.6	474.8	4,619.6
Contract Work	0.0	80.0	8,308.4	11,323.3	5,093.8	1,019.4	25,825.0
Other Direct Costs	0.0	30.5	1,325.8	2,259.5	677.4	228.7	4,521.9
Interest and Escalation	3.8	110.0	831.9	2,524.6	3,442.3	543.6	7,456.3
Contingency	16.4	297.2	1,571.8	3,253.8	1,883.3	522.5	7,545.0
Total	934.3	2,636.7	16,122.8	37,432.4	24,615.3	6,203.5	87,945.0

1.2 Revenue Requirement Impact

Hydro has forecasted the net impact of the selected alternative to its revenue requirement in comparison to the reconstruction of the Charlottetown Diesel Generating Station with continued operation as isolated systems. Compared to the isolated systems option, the interconnection of the southern Labrador communities is expected to generate an incremental revenue requirement increase of \$2.2 million in 2030, due to higher upfront capital costs. As a result of decreased operating, maintenance, fuel, and sustaining capital costs, Hydro forecasts a reduction in net incremental revenue requirements of \$0.8 million in 2035 and \$6.0 million by 2050.² The incremental revenue requirement

¹ Numbers may not add due to rounding.

² Hydro’s insurance claim relating to the 2019 fire at the Charlottetown Diesel Generating Station is ongoing. Should this claim result in a payment to Hydro, such payment will be applied to reduce the revenue requirement associated with this project.

- 1 impacts for the interconnected system supplied by a regional diesel generating station compared to
- 2 isolated systems served by individual plants are presented in Chart 1.

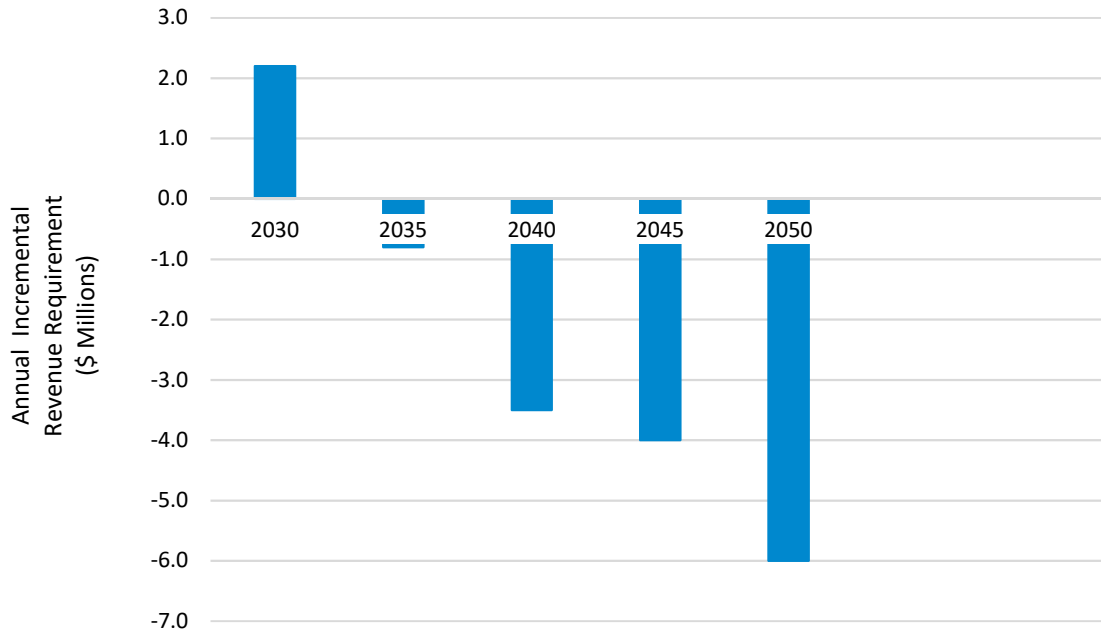

Chart 1: Incremental Revenue Requirements for Interconnection vs Isolated

- 3 Forecast rate impacts associated with changes in the incremental revenue requirements are presented
- 4 in Table 2. The forecast is in comparison to the 2019 Test Year and assumes the incremental revenue
- 5 requirements will be shared between Newfoundland Power Inc. (“Newfoundland Power”) and Rural
- 6 Labrador Interconnected customers in the same proportion in which the rural deficit was allocated in
- 7 the 2019 Cost of Service Study.³

Table 2: Forecast Incremental Rate Impacts (%)⁴

Impact on Revenue Requirement	2030	2035	2040	2045	2050
Newfoundland Power	0.3%	-0.1%	-0.5%	-0.6%	-0.9%
End Consumer ⁵	0.2%	-0.1%	-0.4%	-0.4%	-0.6%
Labrador Interconnected	0.3%	-0.2%	-0.5%	-0.6%	-0.9%

³ Newfoundland Power 96.1% and Rural Labrador Interconnected 3.9%.

⁴ The forecast rate impact of the total project is approximately 1.5% for the end consumer on the Island Interconnected System and 2.0% for consumers on the Labrador Interconnected System. Assumes the average revenue to cost ratio for customers on the Labrador Isolated System in the 2019 Test Year is 24%, which represents their portion of costs recovered through rates.

⁵ Assumes the average revenue to cost ratio for customers on the Labrador Isolated System in the 2019 Test Year is 24%, which represents their portion of costs recovered through rates.

1 **1.3 Impact on Project Schedule**

2 The updated project schedule is shown in Table 3.

Table 3: Project Schedule

Activity	Start Date	End Date
Planning:		
Front-end engineering and project approval	First Quarter 2020	Fourth Quarter 2023
Environmental assessment	First Quarter 2024	First Quarter 2025
Design:		
Detailed design of diesel generating station and distribution	First Quarter 2024	Third Quarter 2025
Procurement:		
Major equipment and construction contracts	Fourth Quarter 2024	Third Quarter 2026
Construction:		
Regional diesel generating station and distribution	Second Quarter 2025	First Quarter 2028
Commissioning:		
Commissioning of equipment	First Quarter 2028	Second Quarter 2028
Closeout:		
Contract and project closeout	Third Quarter 2028	Fourth Quarter 2028



Affidavit

IN THE MATTER OF the *Electrical Power Control Act, 1994, RSNL 1994, Chapter E-5.1 ("EPCA")* and the *Public Utilities Act, RSNL 1990, Chapter P-47 ("Act")*, and regulations thereunder

IN THE MATTER OF an application by Newfoundland and Labrador Hydro ("Hydro") for an order approving the construction of Phase 1 of Hydro's long-term supply plan for southern Labrador, pursuant to Section 41(3) of the *Act*.

AFFIDAVIT

I, Robert Collett, of St. John's in the province of Newfoundland and Labrador, make oath and say as follows:

- 1) I am Vice President, Engineering and NL System Operator for Newfoundland and Labrador Hydro, the applicant named in the attached application.
- 2) I have read and understand the foregoing application.
- 3) To the best of my knowledge, information, and belief, all of the matters, facts, and things set out in this application are true.

SWORN at St. John's in the)
province of Newfoundland and)
Labrador this 5th day of October)
2023 before me:)

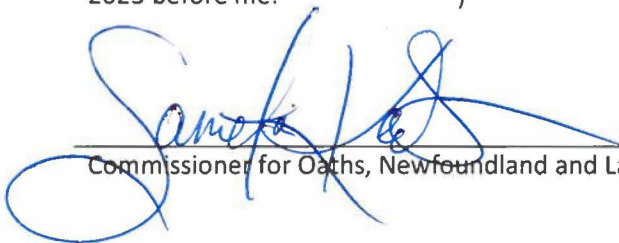

Commissioner for Oaths, Newfoundland and Labrador

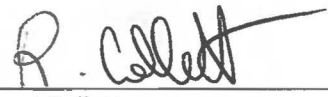

Robert Collett

SAMANTHA KEATS
A Commissioner for Oaths in and for
the Province of Newfoundland and Labrador.
My commission expires on December 31, 2027